

Review of diffraction at HERA

Karel Černý

Charles University in Prague

on behalf of the H1 and ZEUS Collaborations



QCD 15

18th HIGH-ENERGY PHYSICS
INTERNATIONAL CONFERENCE
IN QUANTUM CHROMODYNAMICS (QCD)



HERA

HERA (DESY, Hamburg)
ep collider, 1993-2007

$$E_p = 920 \text{ GeV} \quad E_{e\pm} = 27.5 \text{ GeV}$$

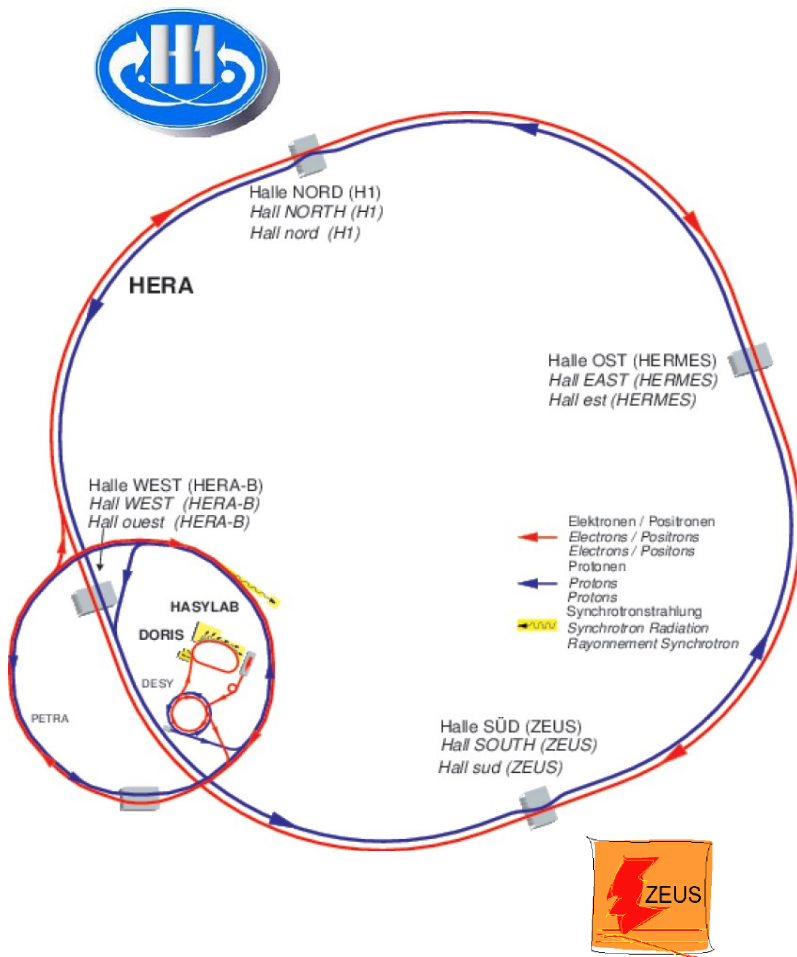

H1 and ZEUS
two multipurpose experiments

HERA I (1993-2000) $\approx 120 \text{ pb}^{-1}$
HERA II (2003-2007) $\approx 380 \text{ pb}^{-1}$
... per experiment

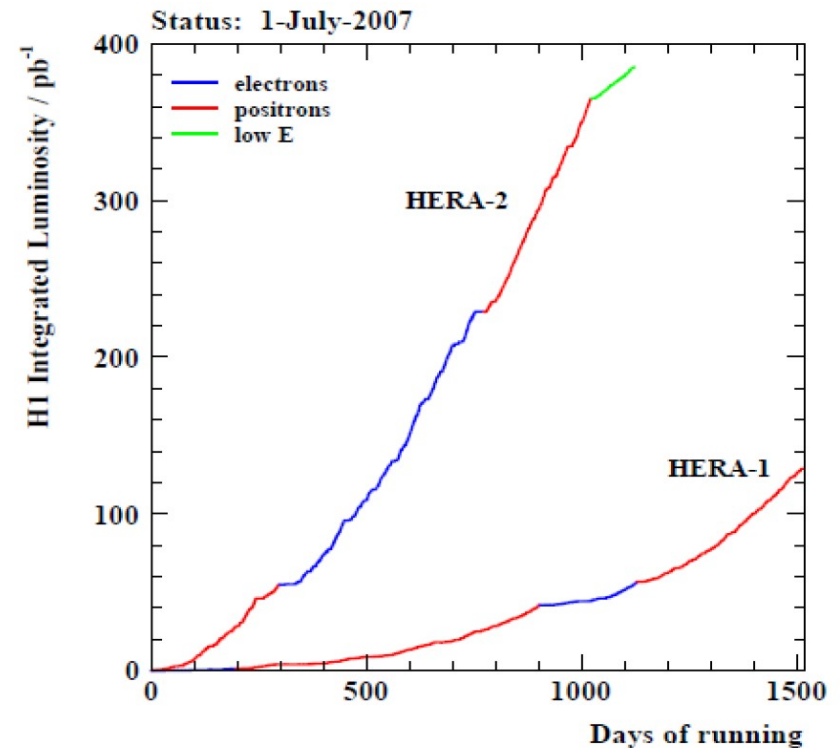

Diffraction in ep

ep interactions proceed mainly via γ^* exchange

$s = (k+P)^2$... CMS energy of collision

$Q^2 = -q^2 = -(k-k')^2$... four-momentum transfer at e vertex

$W = \sqrt{(q+P)^2}$... hadronic c.m.s. energy

$x = \frac{Q^2}{2q \cdot P}$... Bjorken x

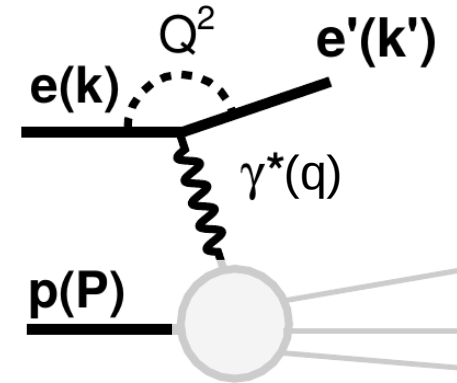

diffraction

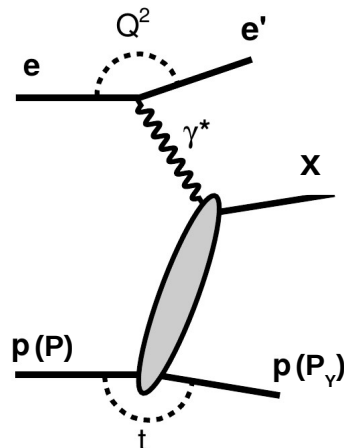

from Regge phenomenology of h-h collisions

$$\sigma_{tot} \propto \sum_k S^{2(\alpha_k(0)-1)}$$

$$\alpha_k(t) = \alpha_k(0) + \alpha'_k t$$

→ trajectory in (t, l) plane

→ l - cplx ang. momentum

$\sigma_{tot}(s)$ described only if vacuum quantum numbers' exchange is included:

→ **Pomeron (IP)** $\alpha_{IP}(t) = 1.08 + 0.25 [\text{GeV}^{-2}] \cdot t$

$t = (P-P_Y)^2$... four-momentum transfer at p vertex

$x_{IP} = \frac{q \cdot (P-P_Y)}{q \cdot P}$... fractional long. mom. loss of proton

Diffraction in ep

ep interactions proceed mainly via γ^* exchange

$s = (k+P)^2$... CMS energy of collision

$Q^2 = -q^2 = -(k-k')^2$... four-momentum transfer at e vertex

$W = \sqrt{(q+P)^2}$... hadronic c.m.s. energy

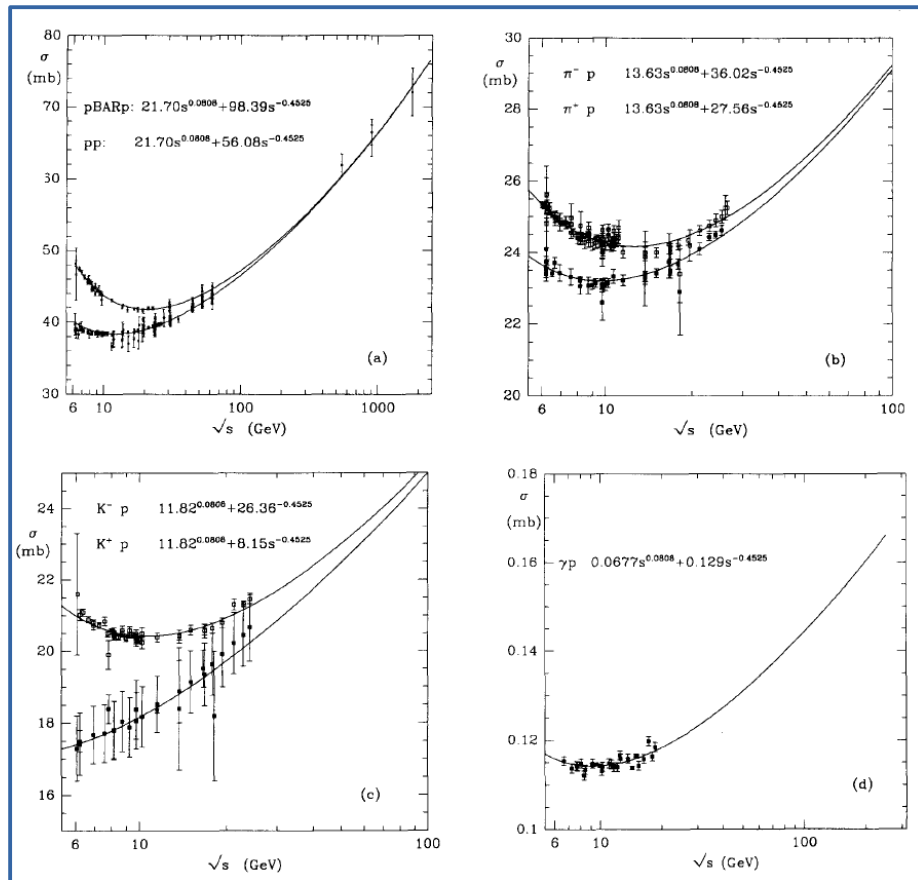
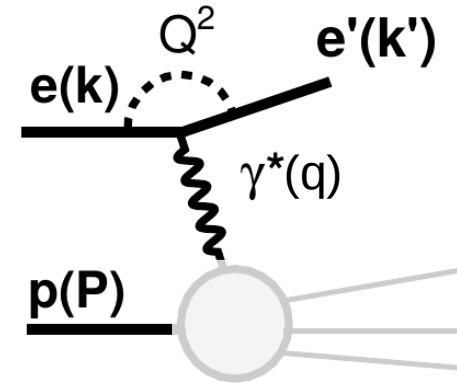

from Regge phenomenology of h-h collisions

$$\sigma_{tot} \propto \sum_k S^{2(\alpha_k(t)-1)}$$

$\alpha_k(t) = \alpha_k(0) + \alpha'_k t$
 \rightarrow trajectory in (t, l) plane
 $\rightarrow l$ - cplx. ang. momentum

$\sigma_{tot}(s)$ described only if vacuum quantum numbers' exchange is included:

\rightarrow **Pomeron (IP)** $\alpha_{IP}(t) = 1.08 + 0.25 [\text{GeV}^{-2}] \cdot t$

Diffraction in ep

main classes of diffractive processes of interest at HERA

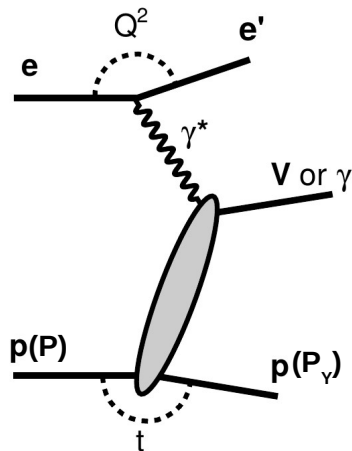

'elastic' VM or DVCS

in some cases with
proton dissociation
 $p \rightarrow Y$, where $M_Y = P_Y^2$

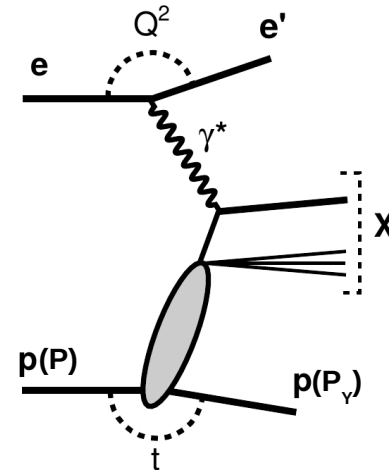

diffractive dissociation

hard diffractive exchange

- whole exchange participates
- mostly ρ , ω , ϕ , ρ' , J/ψ or γ

described in proton rest frame

- VMD model (no hard scale)
- color dipole model (hard scale)

... with relevance for DDIS too

HERA domain

- continuum of masses of X
- only part of diff. exchange participates, $\beta = x / x_{IP}$
- main approach is collinear factorization and DPDFs

Diffraction seen in detectors

due to vacuum quantum exchange

- leading particle at relatively small t
- rapidity distributions of final state (VM, X) separated from leading particle by non-exponentially suppressed gaps – **Large Rapidity Gap (LRG)**

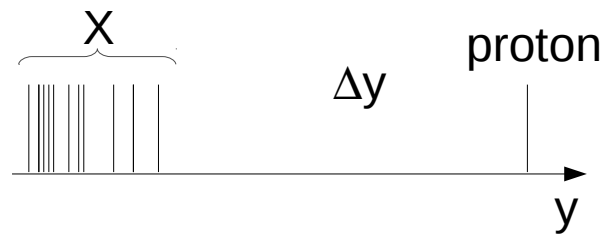

both leading proton tagging or LRG used in H1 and ZEUS

LRG method

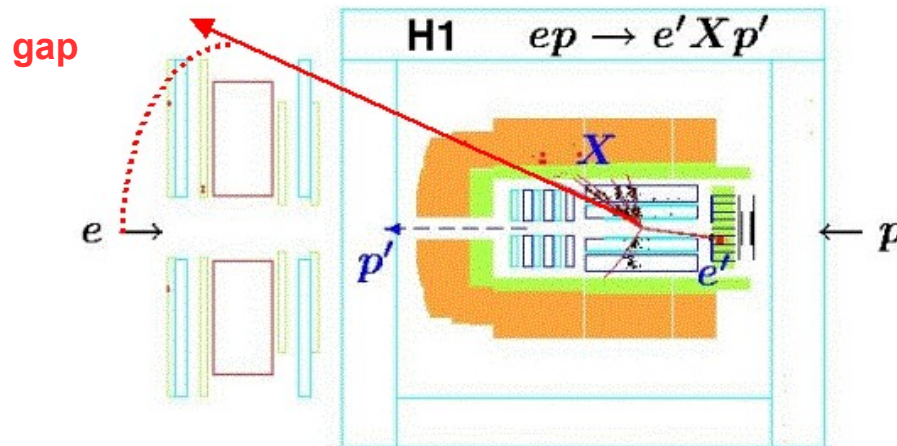

Diffraction seen in detectors

due to vacuum quantum exchange

- leading particle at relatively small t
- rapidity distributions of final state (VM, X) separated from leading particle by non-exponentially suppressed gaps – **Large Rapidity Gap (LRG)**



both leading proton tagging or LRG used in H1 and ZEUS

LRG method

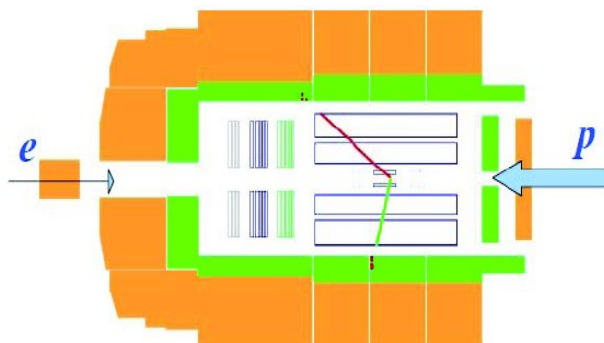

exclusive VM
empty detector otherwise

Diffraction seen in detectors

due to vacuum quantum exchange

- leading particle at relatively small t
- rapidity distributions of final state (VM, X) separated from leading particle by non-exponentially suppressed gaps – **Large Rapidity Gap (LRG)**



both leading proton tagging or LRG used in H1 and ZEUS

LRG method

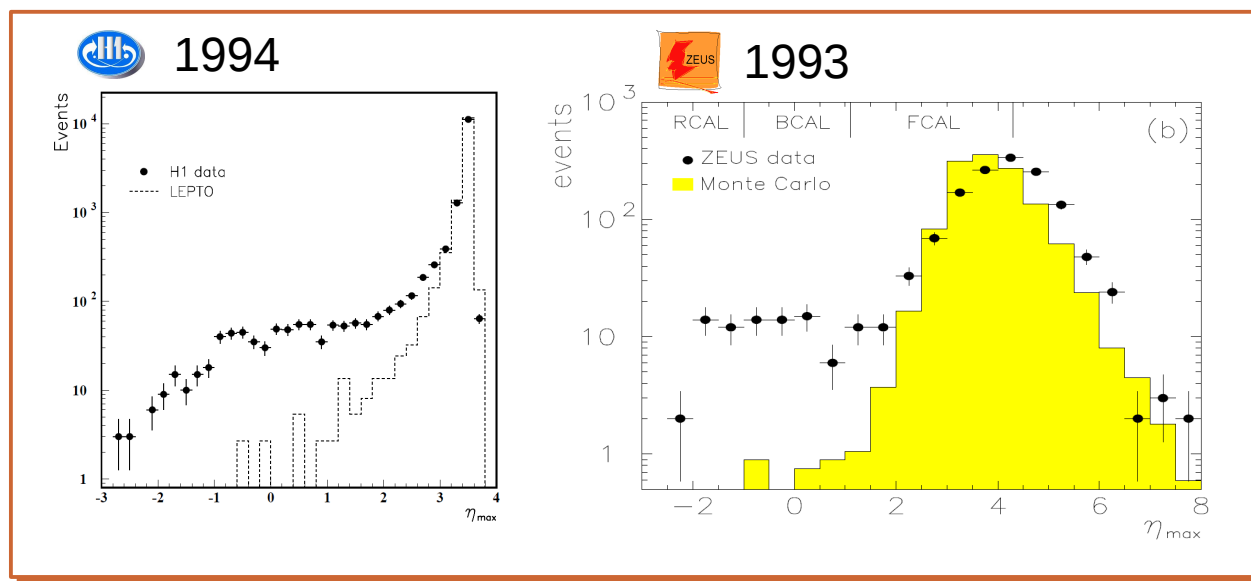

Diffraction seen in detectors

due to vacuum quantum exchange

- leading particle at relatively small t
- rapidity distributions of final state (VM, X) separated from leading particle by non-exponentially suppressed gaps – **Large Rapidity Gap (LRG)**



both leading proton tagging or LRG used in H1 and ZEUS

proton tagging method

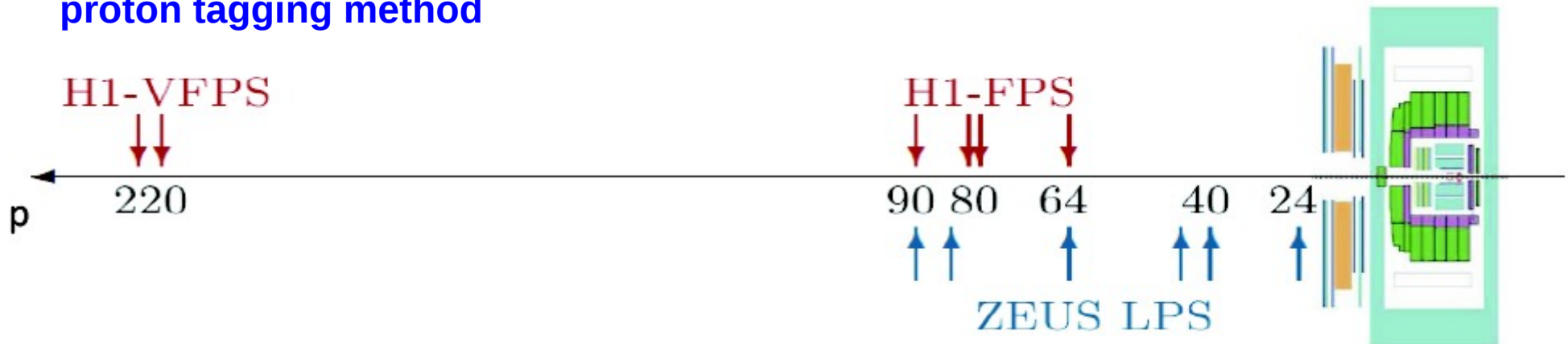

Diffraction seen in detectors

due to vacuum quantum exchange

- leading particle at relatively small t
- rapidity distributions of final state (VM, X) separated from leading particle by non-exponentially suppressed gaps – **Large Rapidity Gap (LRG)**



both leading proton tagging or LRG used in H1 and ZEUS

proton tagging method

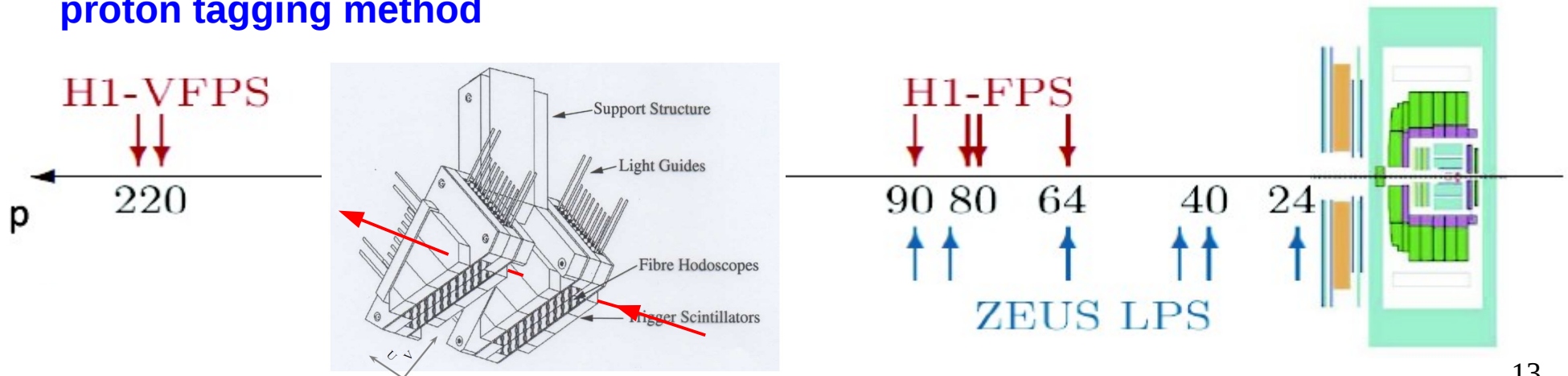

VM production

Quasi elastic vector meson production or DVCS:

$\rho, \omega, \phi, \rho', J/\psi \dots \gamma$

Hard diffractive exchange - whole exchange participates

In terms of Regge theory:

$$\sigma^{\gamma p \rightarrow V p} \sim (W^2)^{2\alpha_{IP}(t)-2} \dots \alpha_{IP}(t) = \alpha_{IP}(0) + \alpha'_{IP} t$$

Donachie-Landshoff ... $\alpha_{IP}(0) \simeq 1.085$

$Y(1S)$... $\alpha_{IP}(0) \simeq 1.6$

Bridge from **no hard scale** \rightarrow **hard scale processes**

... i.e. no pQCD \rightarrow partons and pQCD

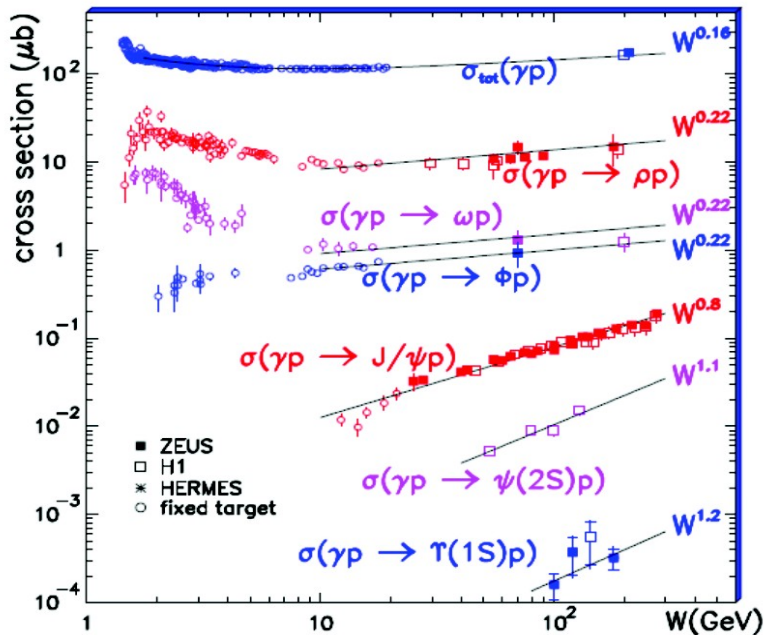
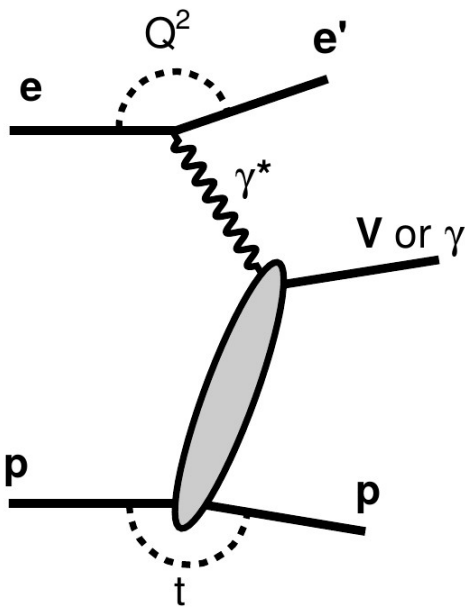

VM production

Quasi elastic vector meson production or DVCS:

$\rho, \omega, \phi, \rho', J/\psi \dots \gamma$

Hard diffractive exchange - whole exchange participates

In terms of Regge theory:

$$\sigma^{\gamma p \rightarrow V p} \sim (W^2)^{2\alpha_{IP}(t)-2} \dots \alpha_{IP}(t) = \alpha_{IP}(0) + \alpha'_{IP} t$$

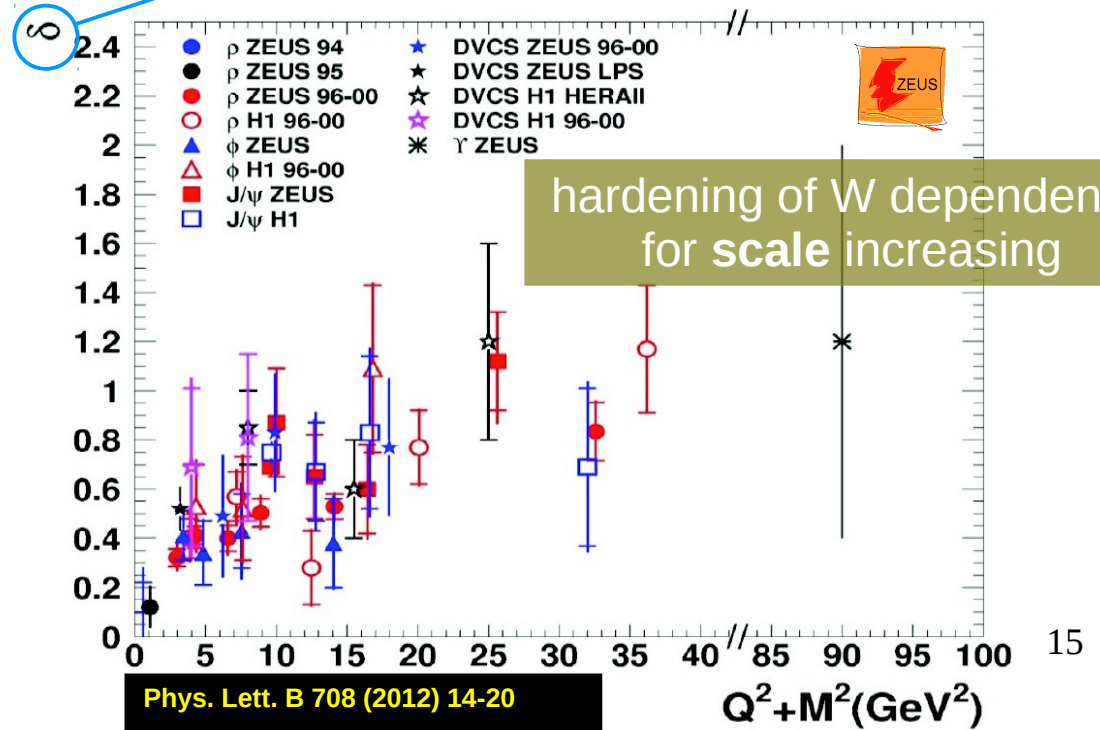
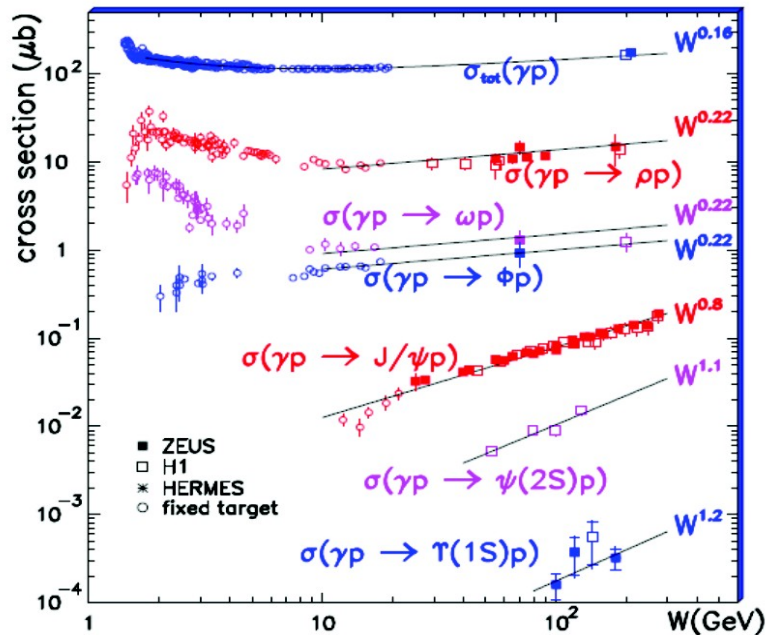
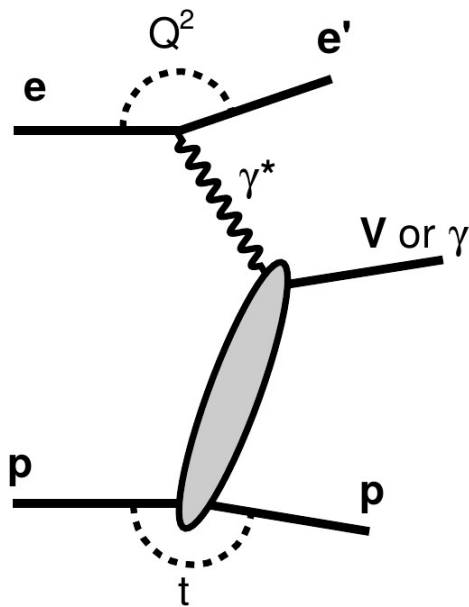

an example: J/ψ in photoproduction

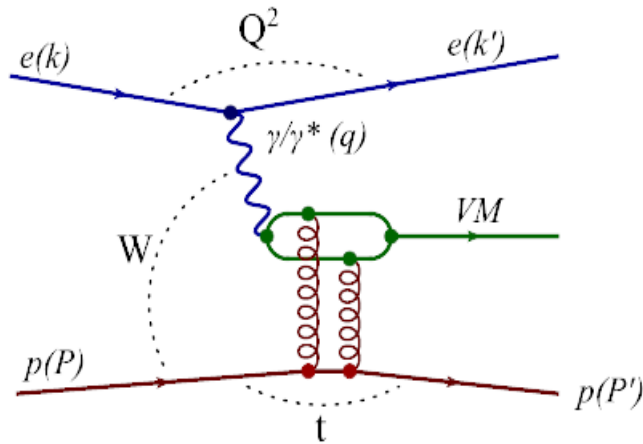

Hard scale present due to J/ψ mass ($Q^2 \sim 0$).

Description with pQCD in proton rest frame with dipole model:

→ in lowest order, IP modeled with pair of gluons

$$\sigma \propto \left[\alpha_s(\mu^2) x g(x, \mu^2) \right]^2$$

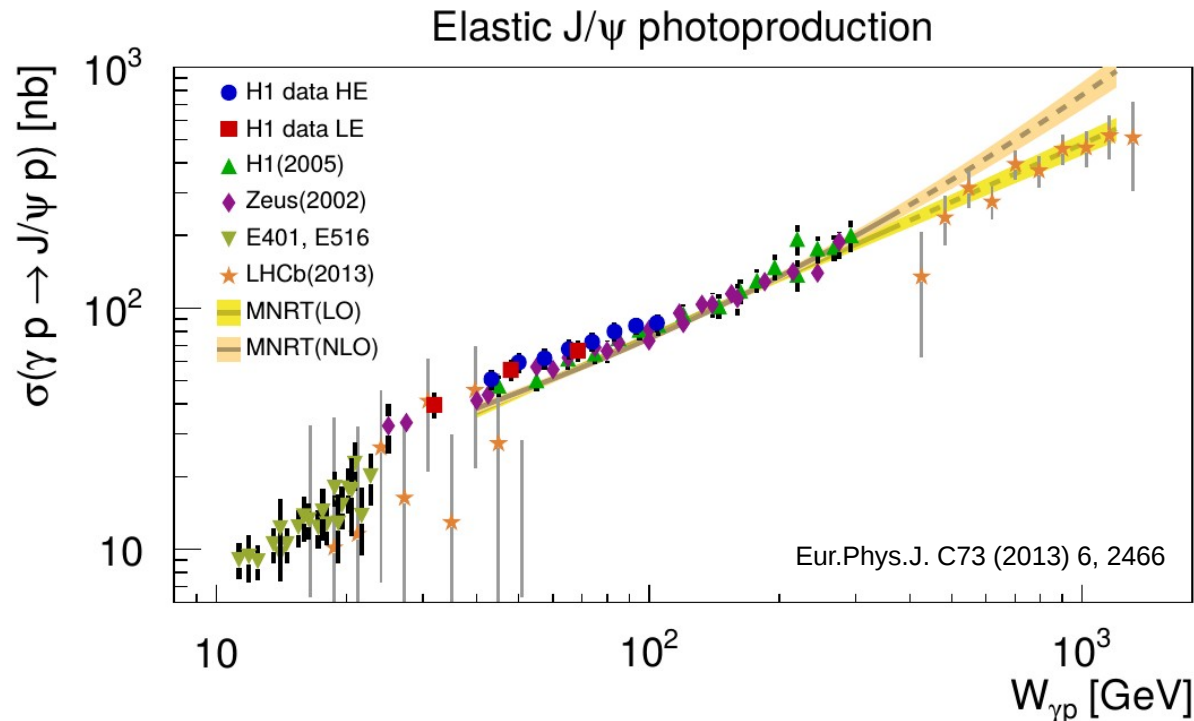

Diffractive dissociation

Diffractive dissociation in DIS

- virtual photon dissociates into system X ($M_X^2 \ll W^2$)
- small momentum transfer to proton, $|t| \ll W^2$
- proton stays intact or dissociates into system Y ($M_Y^2 \ll W^2$)
- large rapidity gap (non-exponentially suppressed) between Y and X
- hard scale present (Q^2, p_T^2, m_Q^2)
 - inclusive
 - jet data
 - open charm / beauty
- represents $\sim 10\%$ of low x DIS σ

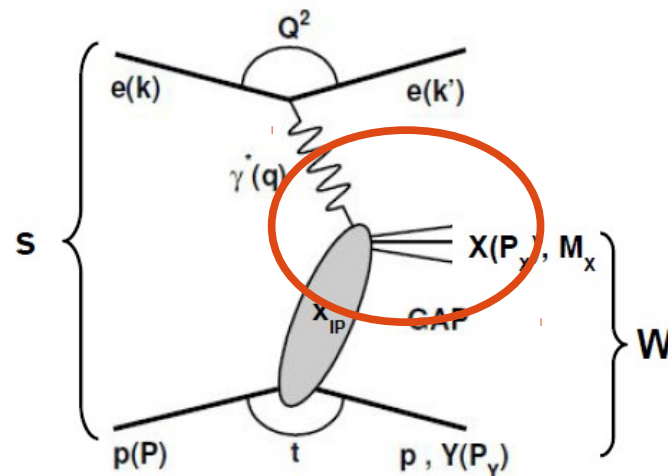

$ep \rightarrow eXY$

Diffractive dissociation

Diffractive dissociation in DIS

- virtual photon dissociates into system X ($M_X^2 \ll W^2$)
- small momentum transfer to proton, $|t| \ll W^2$
- proton stays intact or dissociates into system Y ($M_Y^2 \ll W^2$)
- large rapidity gap (non-exponentially suppressed) between Y and X
- hard scale present (Q^2, p_T^2, m_Q^2)
 - inclusive
 - jet data
 - open charm / beauty
- represents $\sim 10\%$ of low x DIS σ

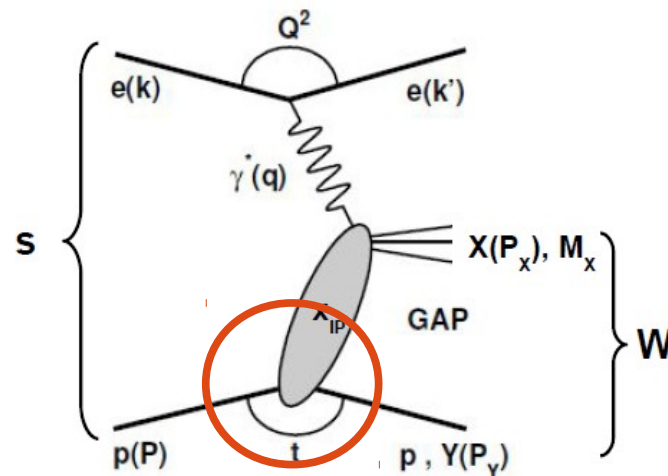

$ep \rightarrow eXY$

Diffractive dissociation

Diffractive dissociation in DIS

- virtual photon dissociates into system X ($M_X^2 \ll W^2$)
- small momentum transfer to proton, $|t| \ll W^2$
- proton stays intact or dissociates into system Y ($M_Y^2 \ll W^2$)
- large rapidity gap (non-exponentially suppressed) between Y and X
- hard scale present (Q^2, p_T^2, m_Q^2)
 - inclusive
 - jet data
 - open charm / beauty
- represents $\sim 10\%$ of low x DIS σ

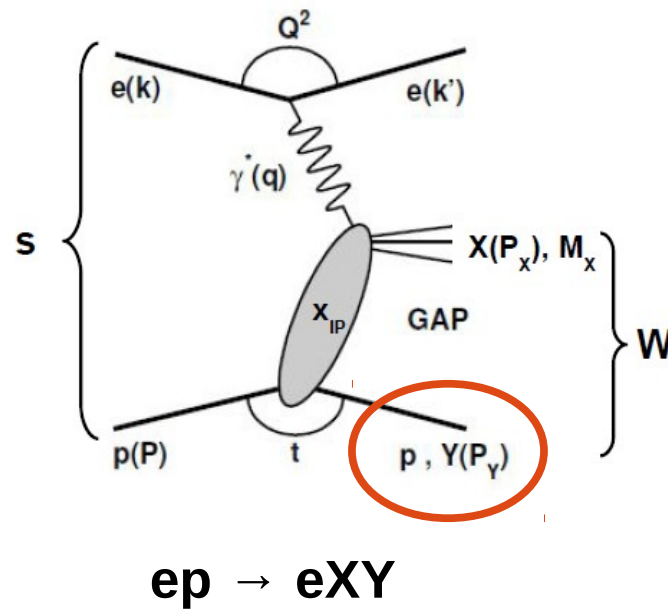

Diffractive dissociation

Diffractive dissociation in DIS

- virtual photon dissociates into system X ($M_X^2 \ll W^2$)
- small momentum transfer to proton, $|t| \ll W^2$
- proton stays intact or dissociates into system Y ($M_Y^2 \ll W^2$)
- large rapidity gap (non-exponentially suppressed) between Y and X
- hard scale present (Q^2, p_T^2, m_Q^2)
 - inclusive
 - jet data
 - open charm / beauty
- represents $\sim 10\%$ of low x DIS σ

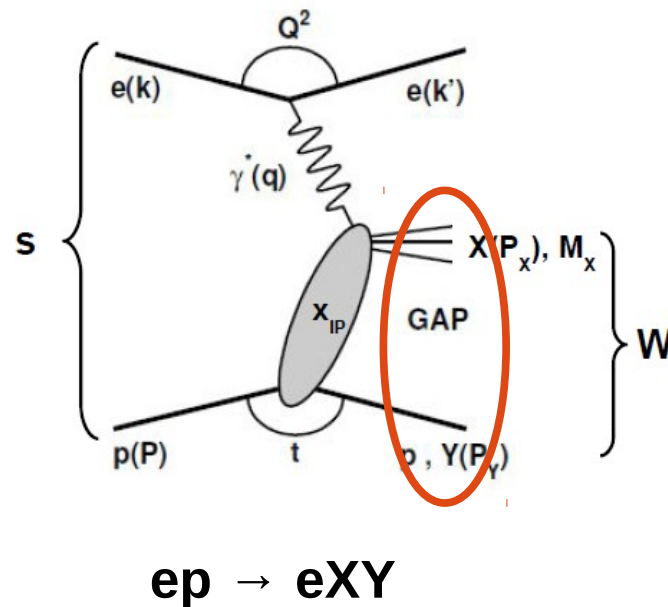

Diffractive dissociation

Diffractive dissociation in DIS

- virtual photon dissociates into system X ($M_X^2 \ll W^2$)
- small momentum transfer to proton, $|t| \ll W^2$
- proton stays intact or dissociates into system Y ($M_Y^2 \ll W^2$)
- large rapidity gap (non-exponentially suppressed) between Y and X
- hard scale present (Q^2, p_T^2, m_Q^2)
 - inclusive
 - jet data
 - open charm / beauty
- represents $\sim 10\%$ of low x DIS σ

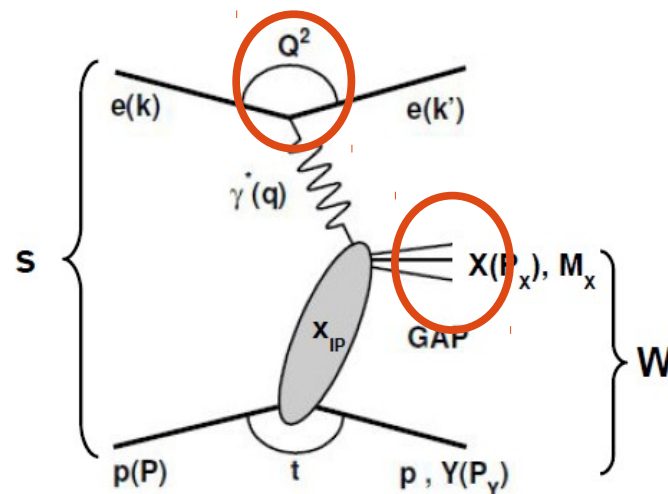

$$ep \rightarrow eXY$$

Diffractive dissociation

Diffractive dissociation in DIS

- virtual photon dissociates into system X ($M_X^2 \ll W^2$)
- small momentum transfer to proton, $|t| \ll W^2$
- proton stays intact or dissociates into system Y ($M_Y^2 \ll W^2$)
- large rapidity gap (non-exponentially suppressed) between Y and X
- hard scale present (Q^2, p_T^2, m_Q^2)
 - inclusive
 - jet data
 - open charm / beauty
- represents $\sim 10\%$ of low x DIS σ

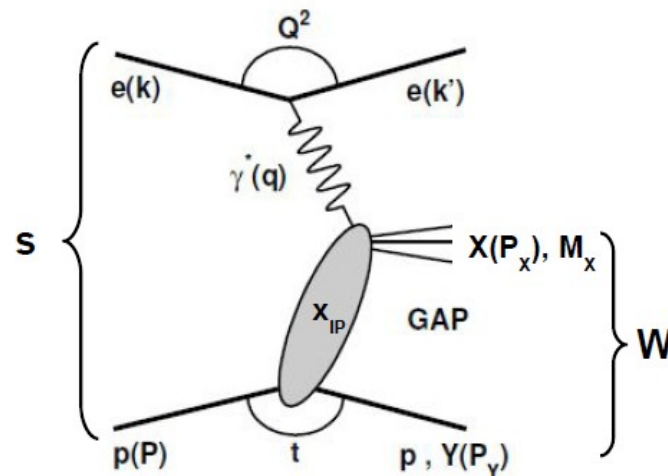

$ep \rightarrow eXY$

an example: DDIS incl x-sections

Combination of H1 and ZEUS data on inclusive diffractive DIS with leading proton

Eur. Phys. J. C72 (2012) 2175, 07/12

$ep \rightarrow eXp$

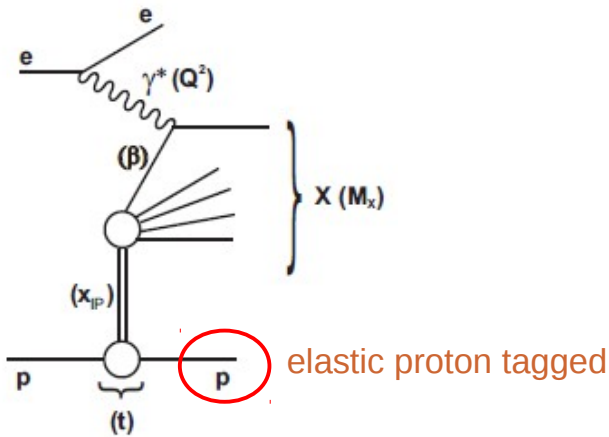

common phase space:

$$2.5 < Q^2 < 200 \text{ GeV}^2$$

$$0.09 < |t| < 0.55 \text{ GeV}^2$$

$$0.00035 < x_P < 0.09$$

$$0.0018 < \beta < 0.816$$

reduced cross sections $\sigma_r^{D(4)} = F_2^{D(4)} - \frac{y^2}{1+(1-y)^2} F_L^{D(4)}$

integrated over t $\sigma_r^{D(3)}(\beta, Q^2, x_P) = \int \sigma_r^{D(4)}(\beta, Q^2, x_P, t) dt$

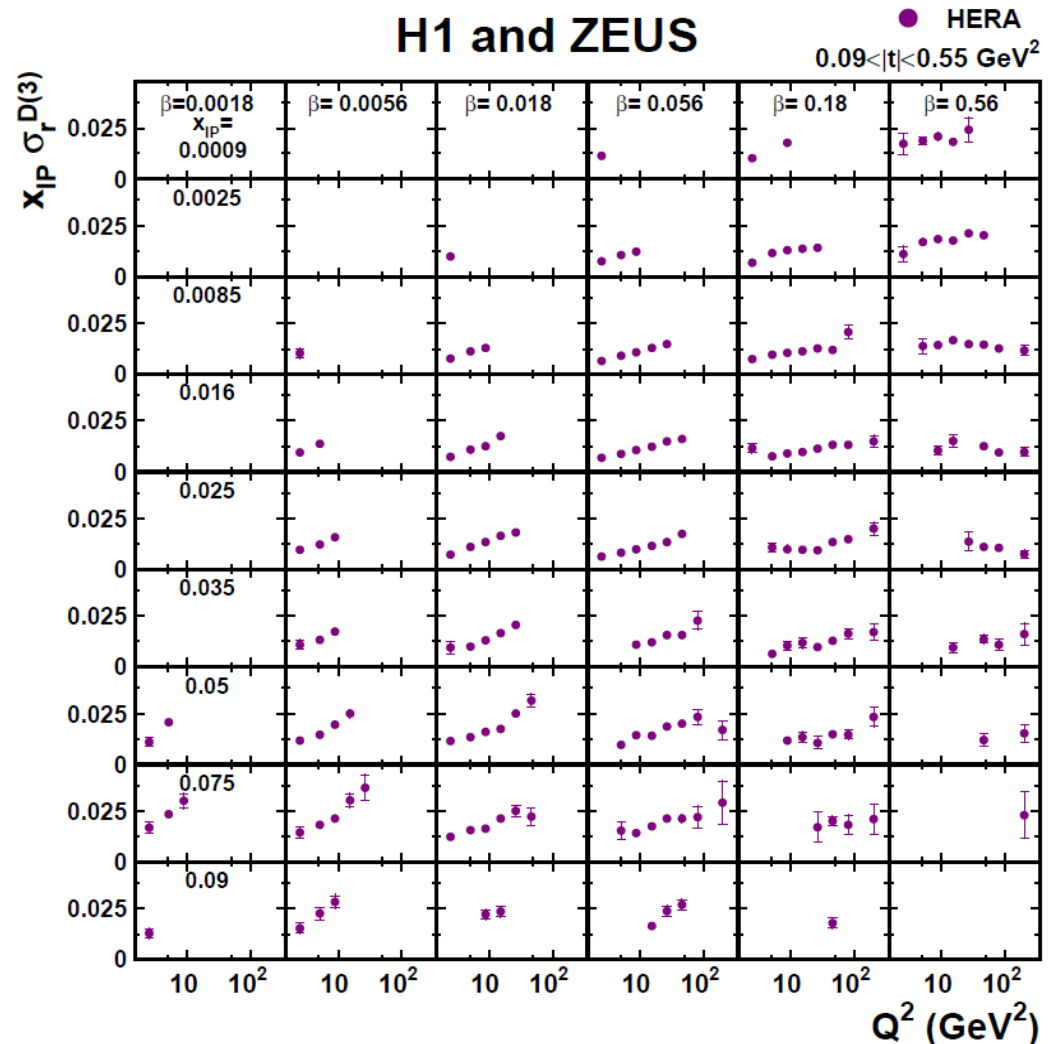

an example: DDIS incl x-sections

Combination of H1 and ZEUS data on inclusive diffractive DIS with leading proton

Eur. Phys. J. C72 (2012) 2175, 07/12

reduced cross sections $\sigma_r^{D(4)} = F_2^{D(4)} - \frac{y^2}{1+(1-y)^2} F_L^{D(4)}$

integrated over t $\sigma_r^{D(3)}(\beta, Q^2, x_P) = \int \sigma_r^{D(4)}(\beta, Q^2, x_P, t) dt$

ep → eXp

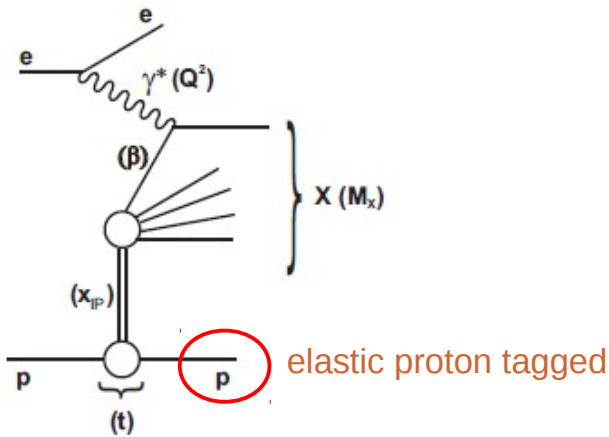

common phase space:

$$2.5 < Q^2 < 200 \text{ GeV}^2$$

$$0.09 < |t| < 0.55 \text{ GeV}^2$$

$$0.00035 < x_P < 0.09$$

$$0.0018 < \beta < 0.816$$

combined measurement more precise than individual ones

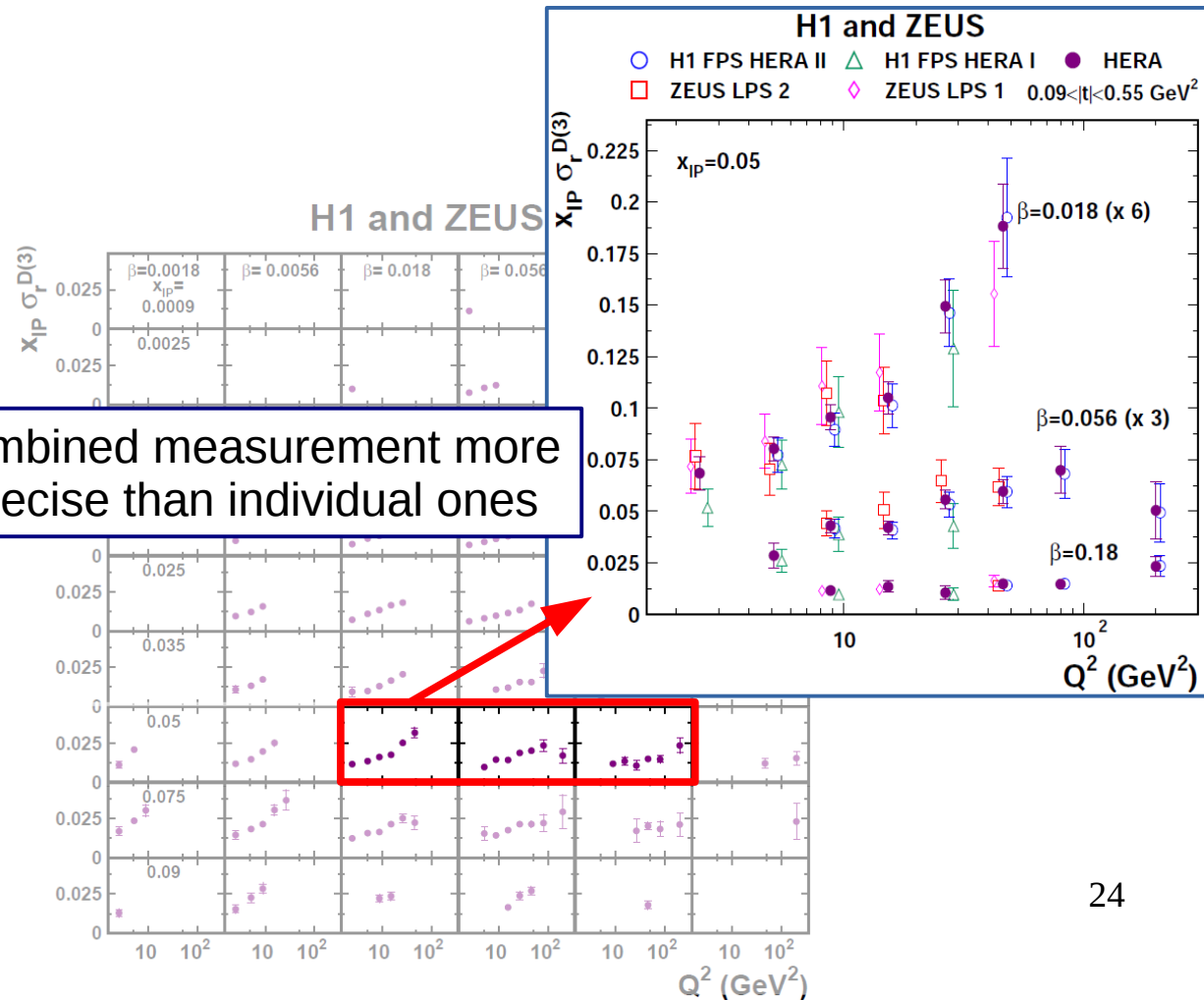

Diffractive PDFs

Most used approach to model various features of diffractive DIS.

Analogy with proton PDFs

central assumption

Collinear factorization Collins, valid for diffractive DIS

→ diffractive parton distribution functions (DPDFs)

→ QCD based predictions for X states

$$d\sigma^{ep \rightarrow e X p}(x, Q^2, x_{IP}, t) = \sum_i \underbrace{f_i^D(x, Q^2, x_{IP}, t)} \otimes \underbrace{d\hat{\sigma}(x, Q^2)}$$

optionally

Resolved Pomeron approach Ingelman and Schlein

→ virtual photon interacts with partonic diffractive exchange

→ leading proton kinematics (t, x_{IP}) treated separately

aka **Proton vertex factorization**

$$f_i^D(x, Q^2, x_{IP}, t) = \underbrace{f_{IP/p}(x_{IP}, t)} \cdot \underbrace{f_i(\beta, Q^2)}$$

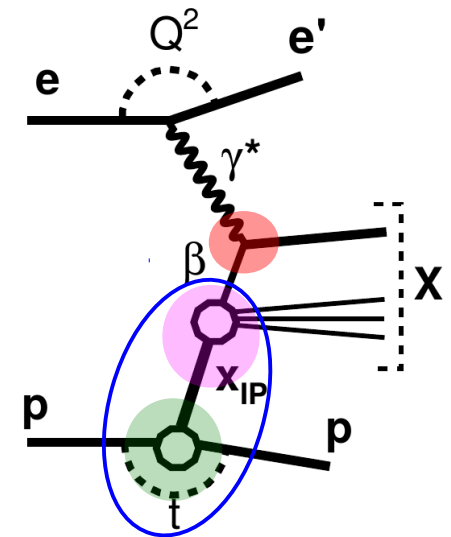

Diffractive PDFs

Extracted mostly from:

- inclusive data $ep \rightarrow eXY$
- $ep \rightarrow eXY$ with jets in the final state
(another constraint on gluon DPDF)

Can be improved by:

- combination of diffraction selection methods
- combinations of data from H1 and ZEUS

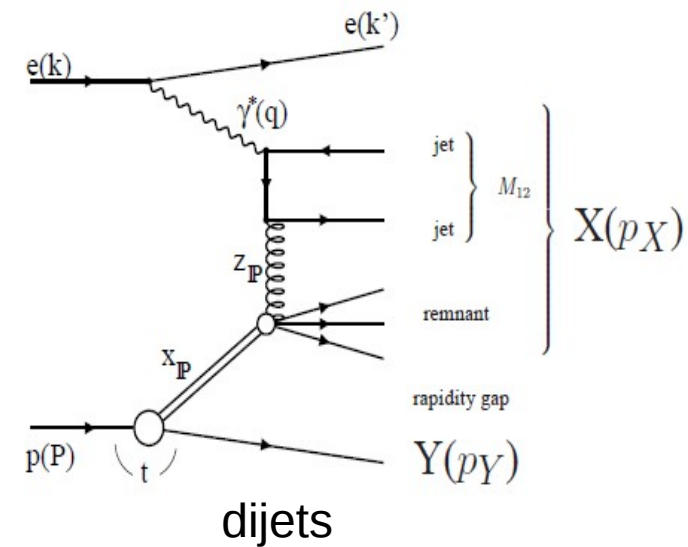
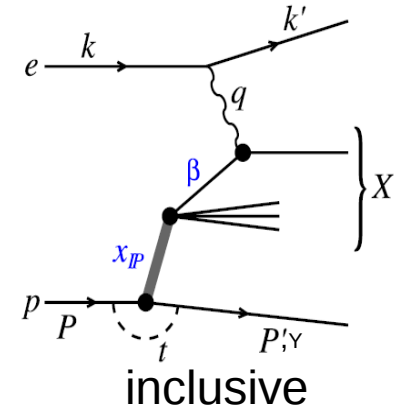

Diffractive PDFs

It's the gluon that dominates diffractive PDFs

a summary of recent, most used, DPDF fits from



and

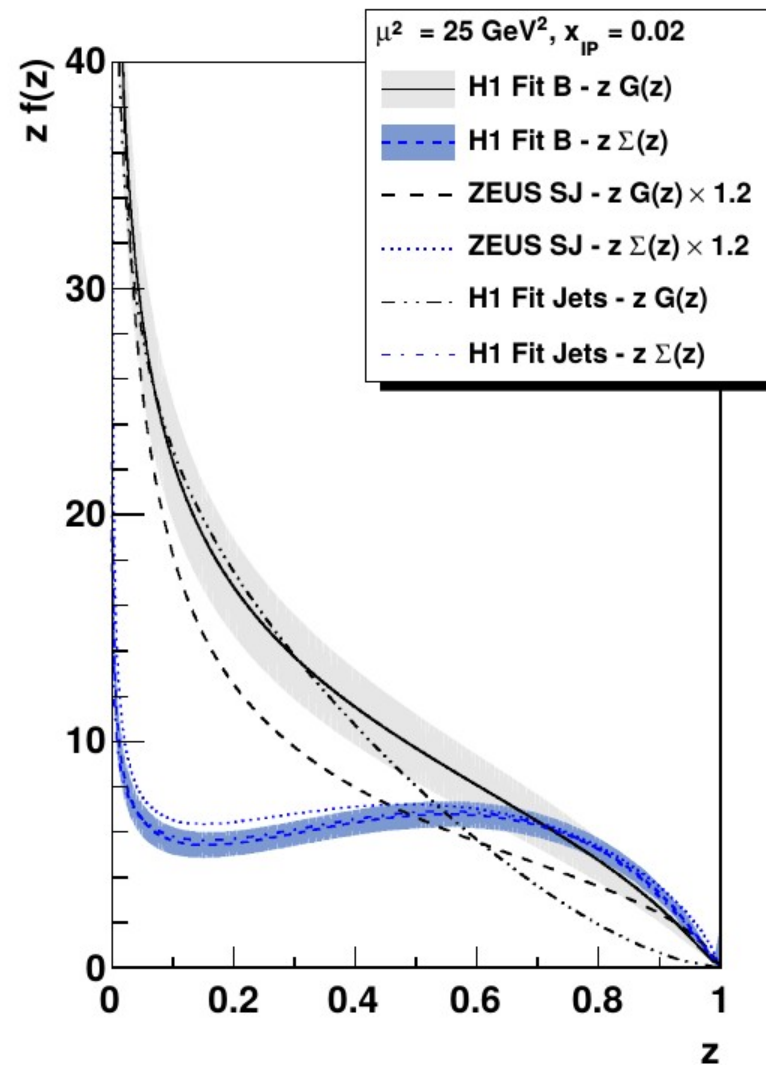
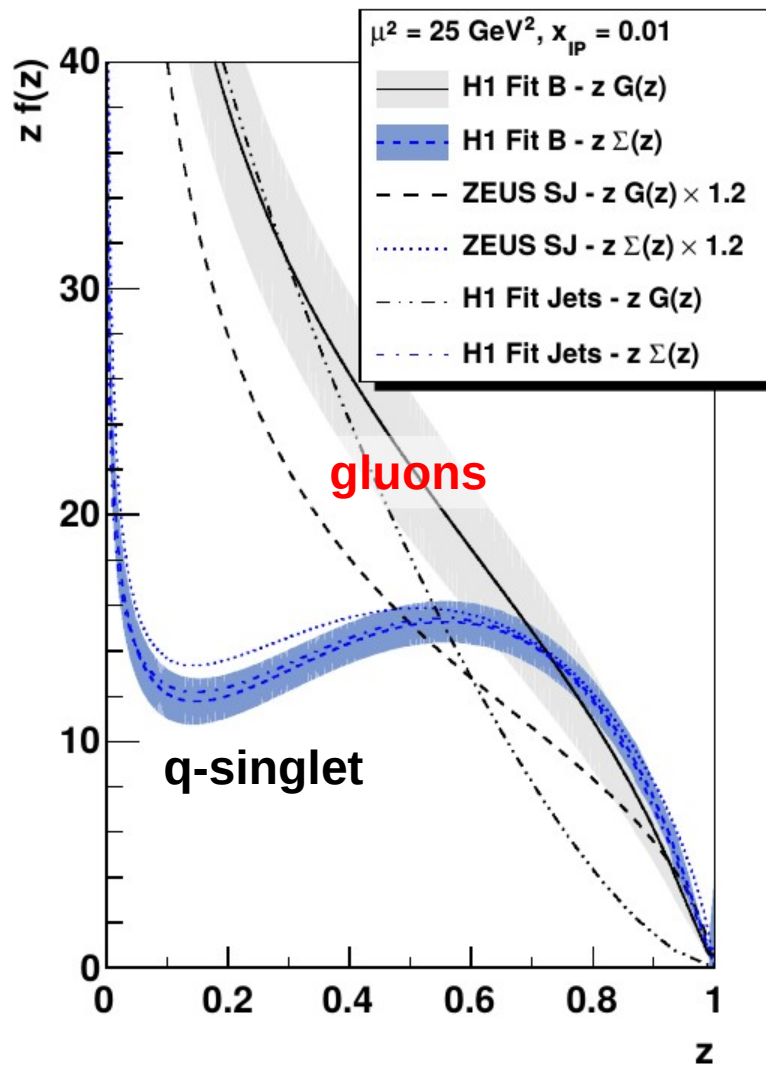

Use of DPDFs: dijets in DDIS

here increased sensitivity to non-DGLAP effects

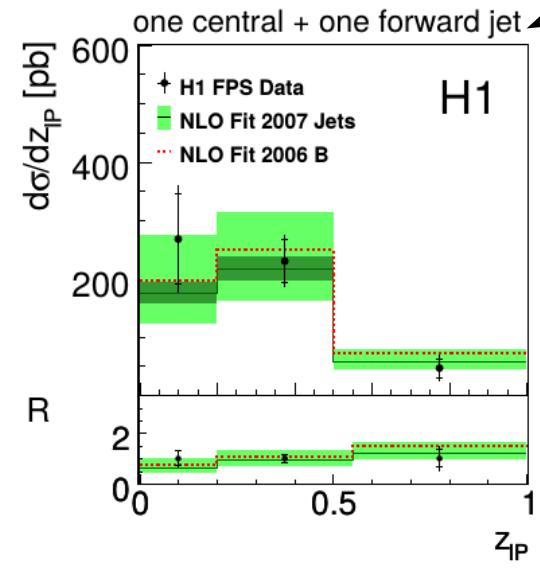
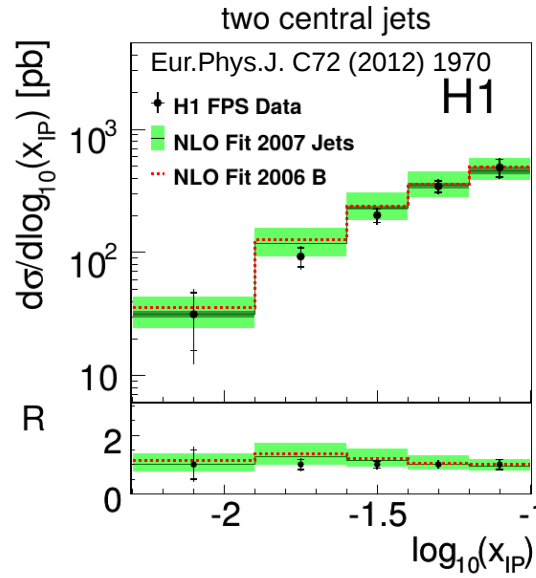
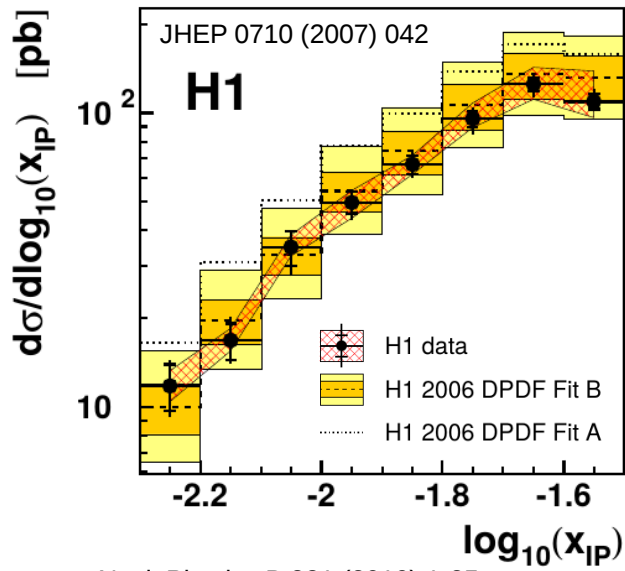

Nucl. Physics B 831 (2010) 1-25

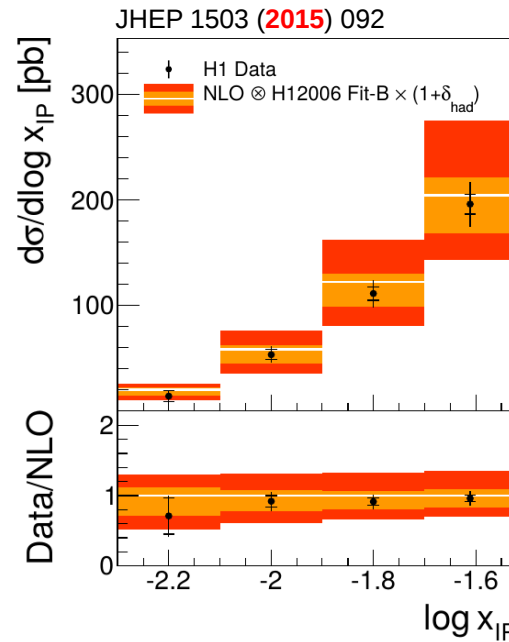
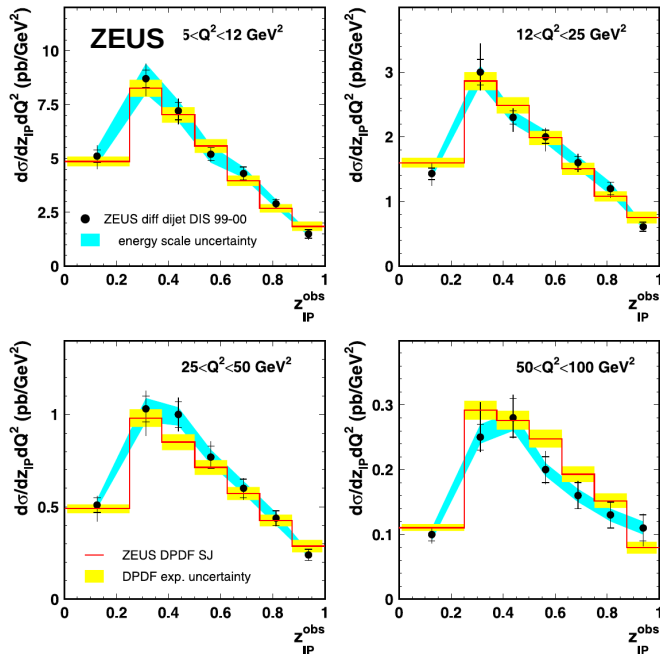

precision of these data allowed to extract α_s which is in agreement with world average

- not a competitive means for extraction α_s
- supports readiness of the measurement for inclusion to DPDF fits

Use of DPDFs: open charm in DDIS

open charm with D^*

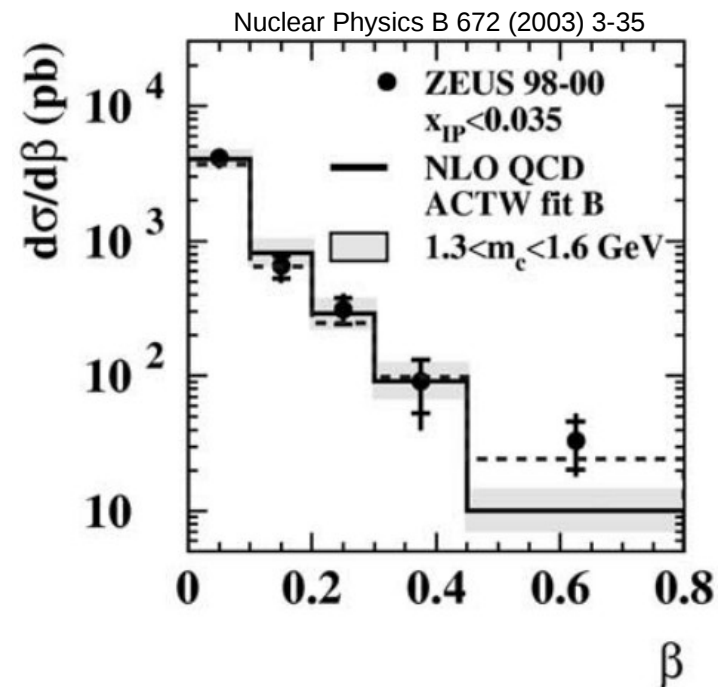
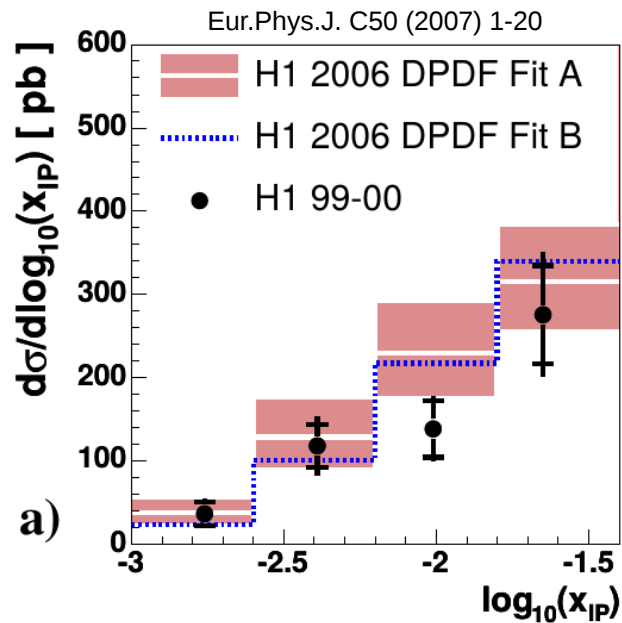
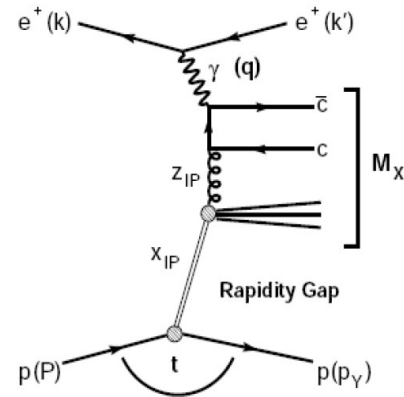

Test of proton vertex factorization in DDIS

Test of soft Regge phenomenology in presence of hard scale

LRG data used to extract $\alpha_{IP}(0)$ for different Q^2 in DDIS

→ absence of Q^2 dependence of $\alpha_{IP}(0)$

→ higher IP intercept to that of Donachie-Landshoff: $\alpha_{IP}(0) \simeq 1.085$

→ still lower than those of hard-exclusive processes: $\alpha_{IP}(0) > 1.2$

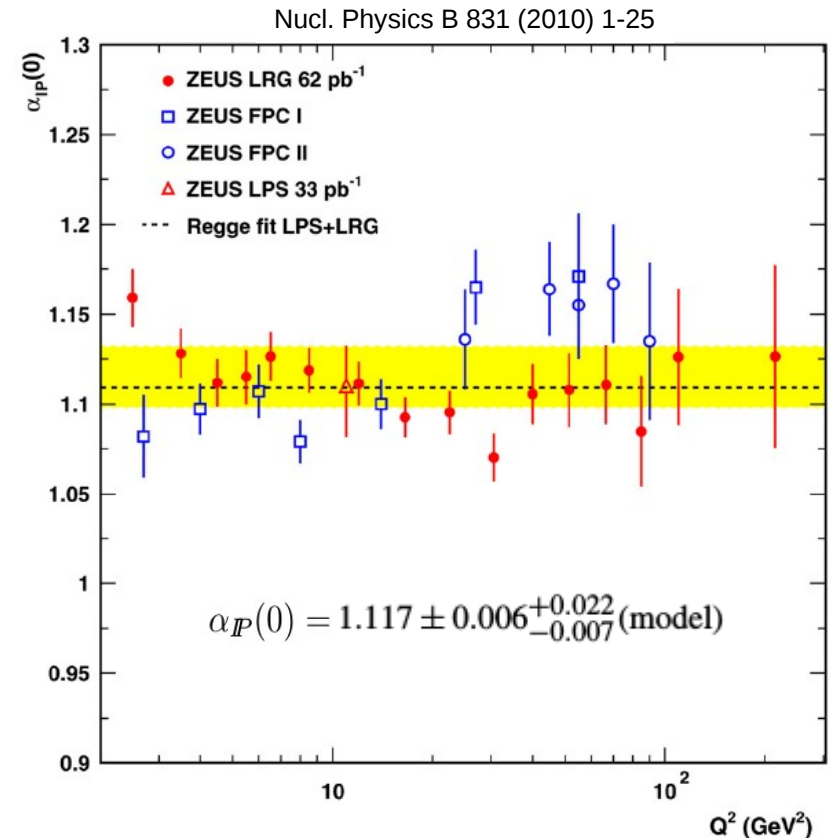
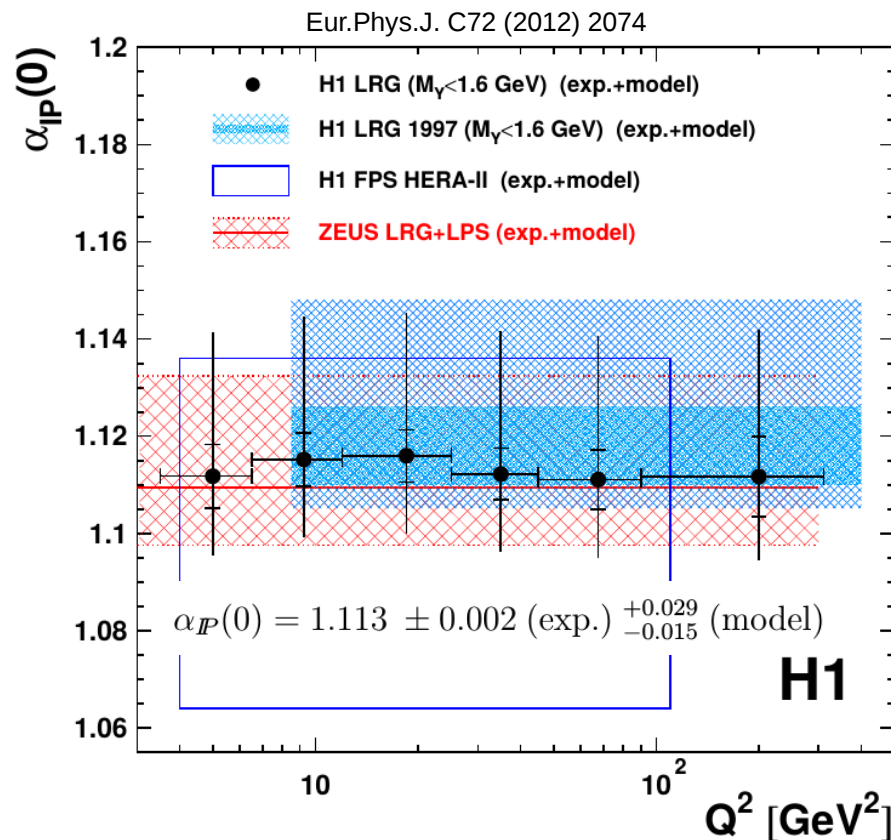

Universality of DPDFs

! DPDFs are not portable to diffractive hadron-hadron (pp) processes !

→ order of magnitude overestimation of predicted pp dijet rates

Factorization breaking in diffractive dijet production

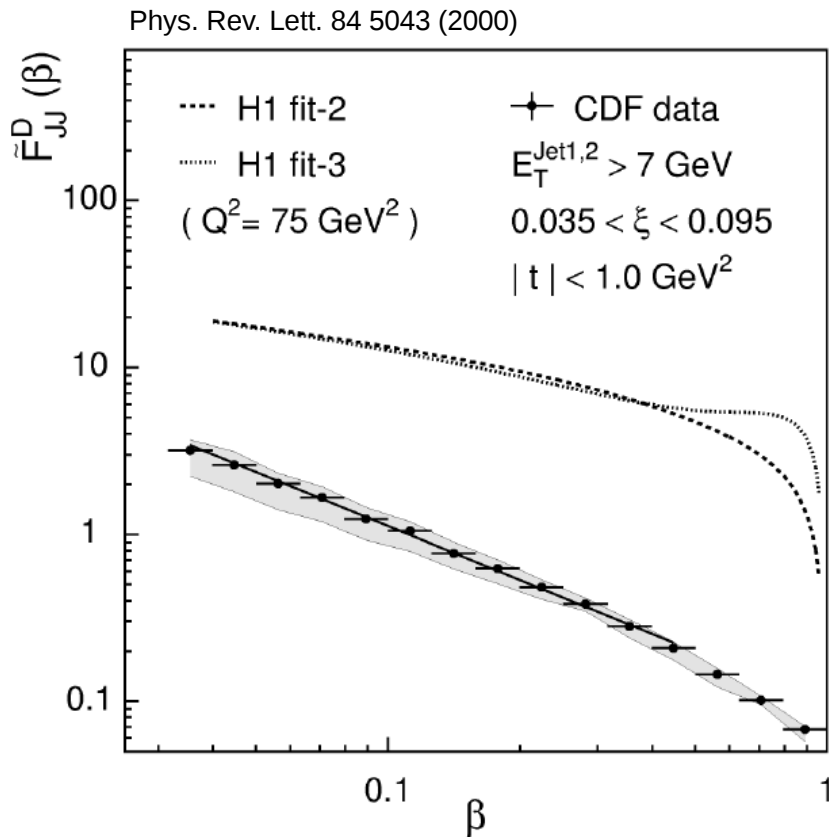

absorptive effects occur

→ aka **rescattering** or **unitarity corrections**

→ several approaches exist to calculate so called **Survival probability $\langle S^2 \rangle$**

... i.e. probability of diffractive event to retain the diffractive signature

Tested in diffractive dijet photoproduction at HERA

Universality of DPDFs

! DPDFs are not portable to diffractive hadron-hadron (pp) processes !

→ order of magnitude overestimation of predicted pp dijet rates

Factorization breaking in diffractive dijet production

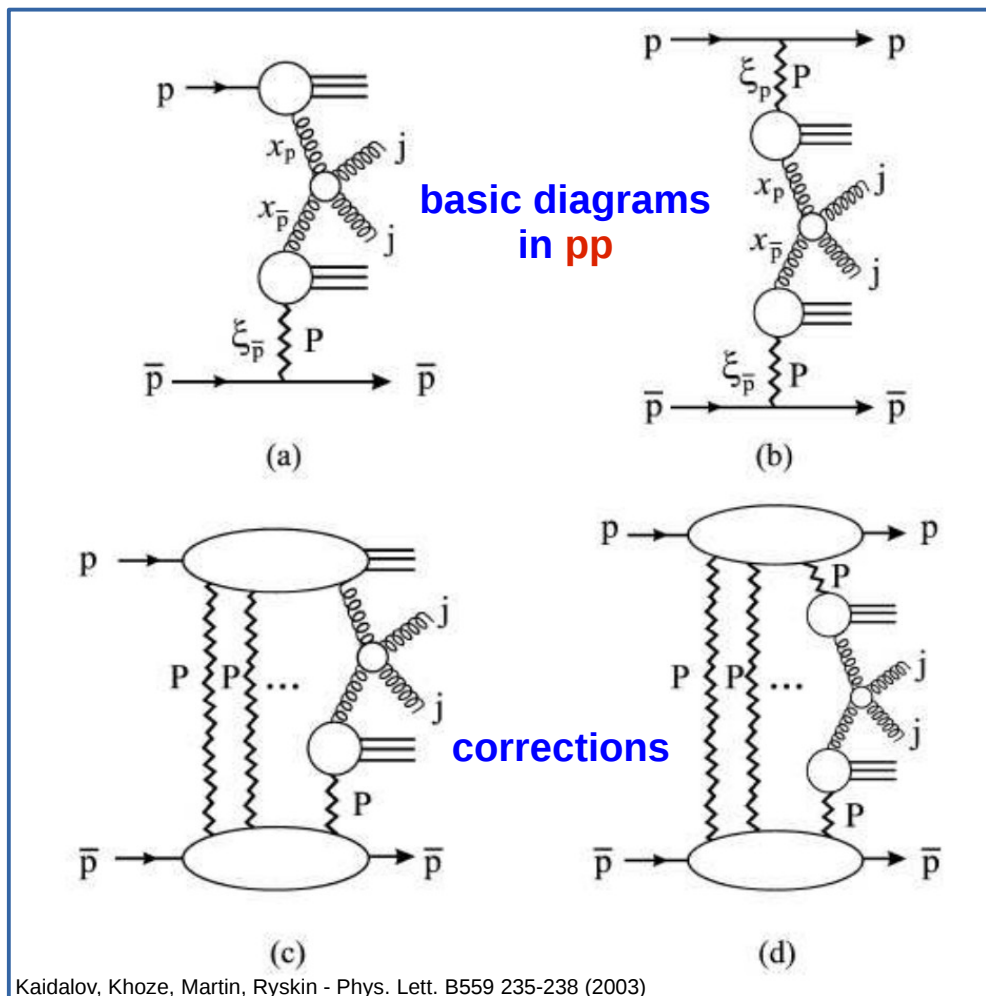

Kaidalov, Khoze, Martin, Ryskin - Phys. Lett. B559 235-238 (2003)

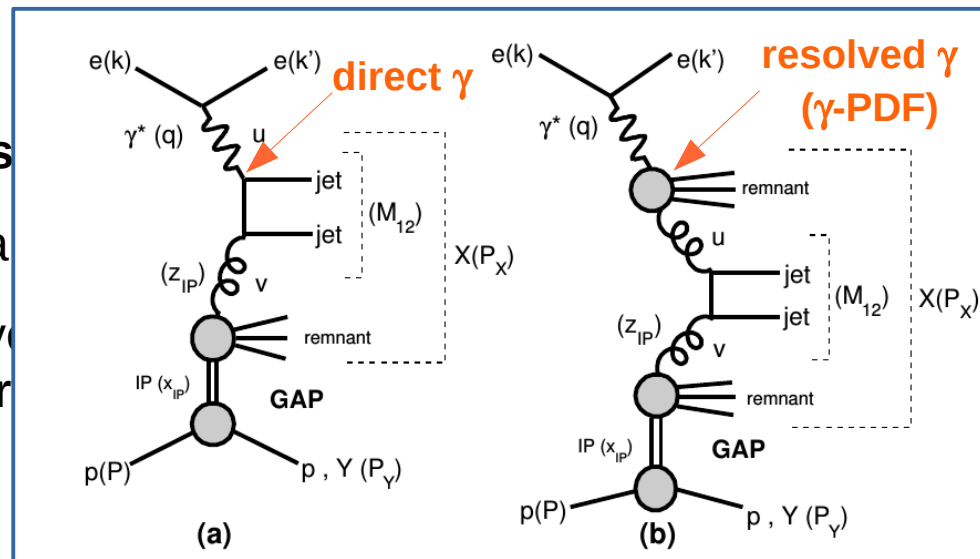

basic diagrams in γp

Tested in diffractive dijet photoproduction at HERA

Dijets in diffractive photoproduction

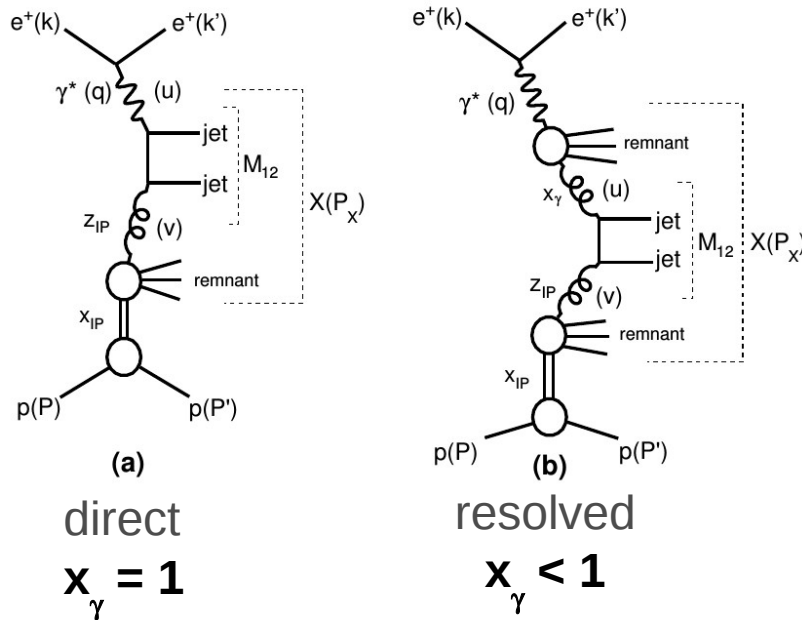

photoproduction regime

- $Q^2 \sim 0$... electron at low angle
- hard scale provided by p_T

in LO

- direct γ DIS-like
- resolved γ pp-like

x_γ fraction $x_\gamma = \frac{P \cdot u}{P \cdot q}$

- allows to classify processes ... up to smearing

studies by H1 and ZEUS

- H1: LRG analyses 2007(Php,DIS), 2010(Php) ... latest leading proton 2015(Php, DIS)
- ZEUS: LRG analysis 2010 (Php)

Dijets in diffractive photoproduction and DIS with leading proton

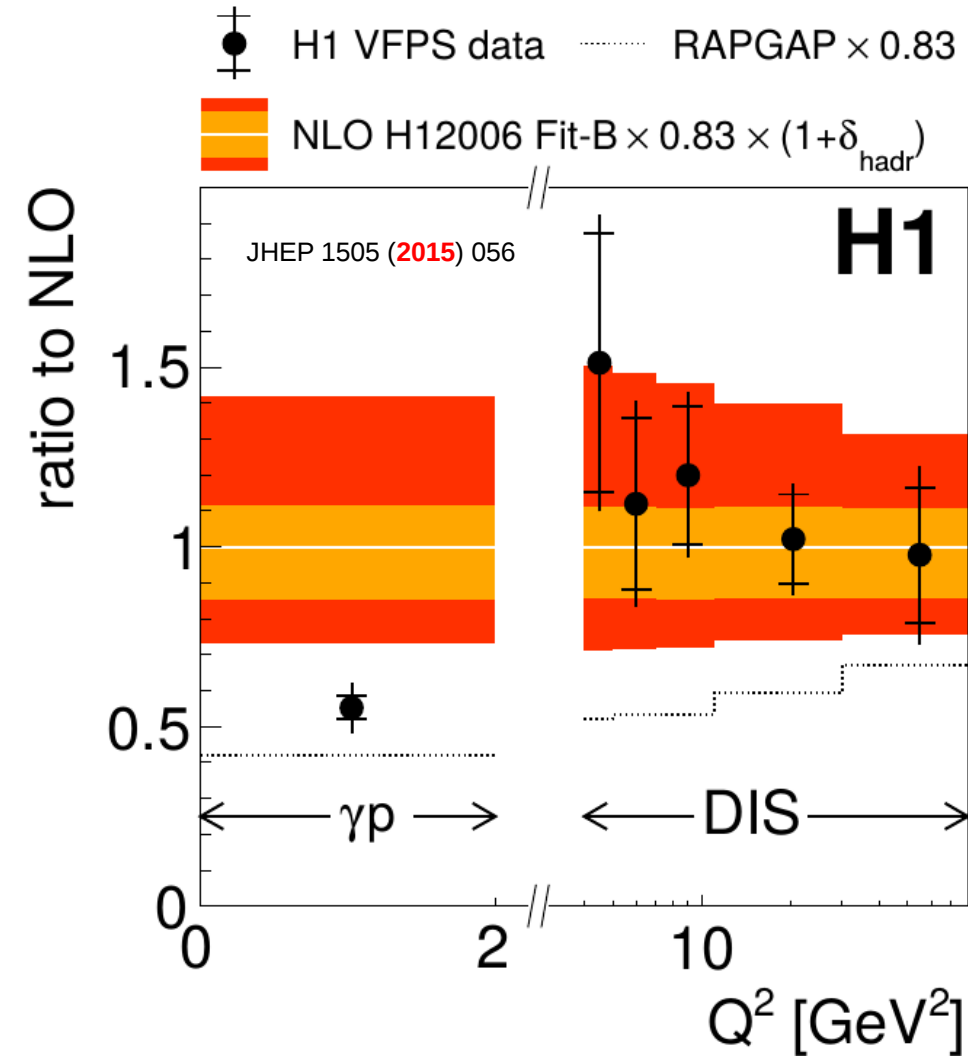

	Photoproduction	DIS
Event kinematics	$Q^2 < 2 \text{ GeV}^2$	$4 \text{ GeV}^2 < Q^2 < 80 \text{ GeV}^2$
		$0.2 < y < 0.7$
Diffractive phase space		$0.010 < x_P < 0.024$
		$ t < 0.6 \text{ GeV}^2$
		$z_P < 0.8$
Jet phase space		$E_T^{\text{jet1}} > 5.5 \text{ GeV}$
		$E_T^{\text{jet2}} > 4.0 \text{ GeV}$
		$-1 < \eta^{\text{jet1,2}} < 2.5$

measured suppression $\langle S^2 \rangle$

data/NLO

$$\gamma p \quad 0.551 \pm 0.078 \text{ (data)}_{-0.149}^{+0.230} \text{ (theory)}$$

$$\text{DIS} \quad 1.08 \pm 0.11 \text{ (data)}_{-0.29}^{+0.45} \text{ (theory)}$$

Dijets in diffractive photoproduction and DIS with leading proton

⊕ H1 VFPS data

NLO H12006 Fit-B $\times 0.83 \times (1 + \delta_{\text{hadr}})$



GRV γ -PDF



AFG γ -PDF

$\mu^2 = \langle E_T^{*\text{jet}} \rangle^2 + Q^2$

$\mu^2 = (E_T^{*\text{jet}1})^2 + Q^2/4$

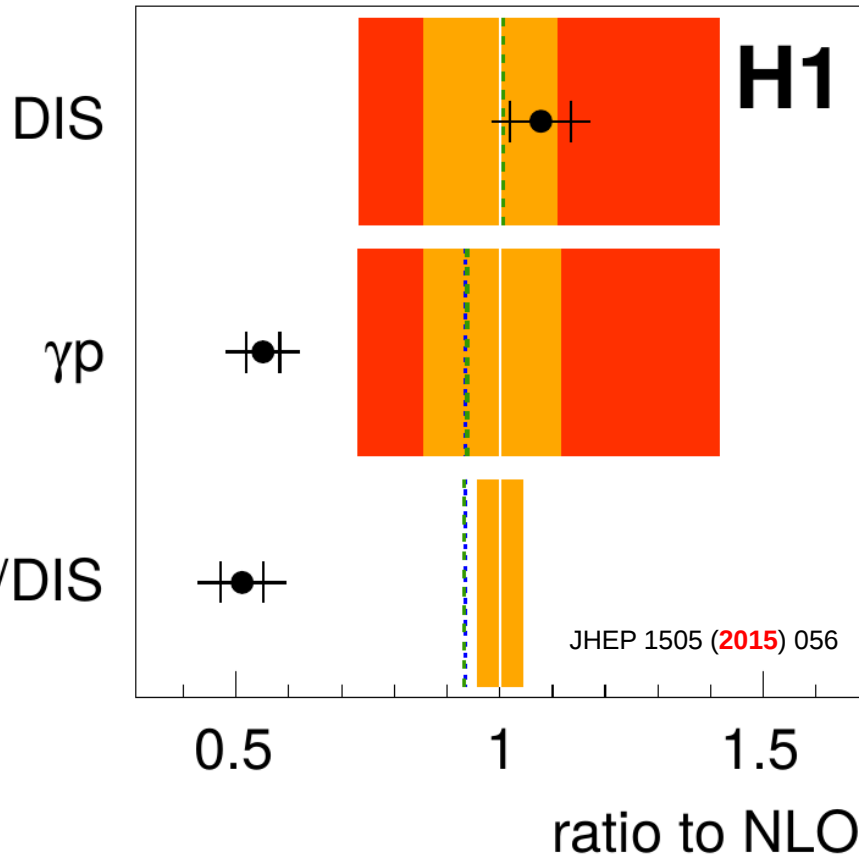

	Photoproduction	DIS
Event kinematics	$Q^2 < 2 \text{ GeV}^2$	$4 \text{ GeV}^2 < Q^2 < 80 \text{ GeV}^2$ $0.2 < y < 0.7$
Diffractive phase space		$0.010 < x_P < 0.024$ $ t < 0.6 \text{ GeV}^2$ $z_P < 0.8$
Jet phase space		$E_T^{*\text{jet}1} > 5.5 \text{ GeV}$ $E_T^{*\text{jet}2} > 4.0 \text{ GeV}$ $-1 < \eta^{\text{jet}1,2} < 2.5$

measured suppression $\langle S^2 \rangle$

data/NLO

$$\gamma p \quad 0.551 \pm 0.078 \text{ (data)}_{-0.149}^{+0.230} \text{ (theory)}$$

$$\text{DIS} \quad 1.08 \pm 0.11 \text{ (data)}_{-0.29}^{+0.45} \text{ (theory)}$$

double ratio of γp to DIS in data and NLO

$$0.511 \pm 0.085 \text{ (data)}_{-0.021}^{+0.022} \text{ (theory)}$$

$$0.547 \quad \text{with AFG } \gamma\text{PDF}$$

$$0.548 \quad \text{with scale } \mu^2 = (E_T^{*\text{jet}1})^2 + Q^2/4$$

Summary on dijets in diffractive photoproduction

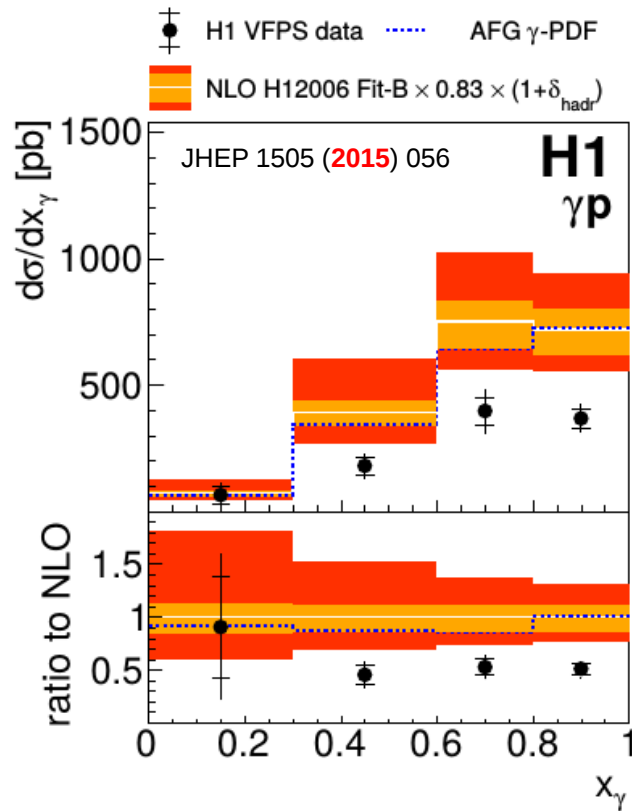

H1 results agree among themselves
 different experimental methods used
 ... LRG / LP
 ... tagged / untagged electron

x_γ independent suppression observed

Nucl. Phys. B 831 (2010) 1-25

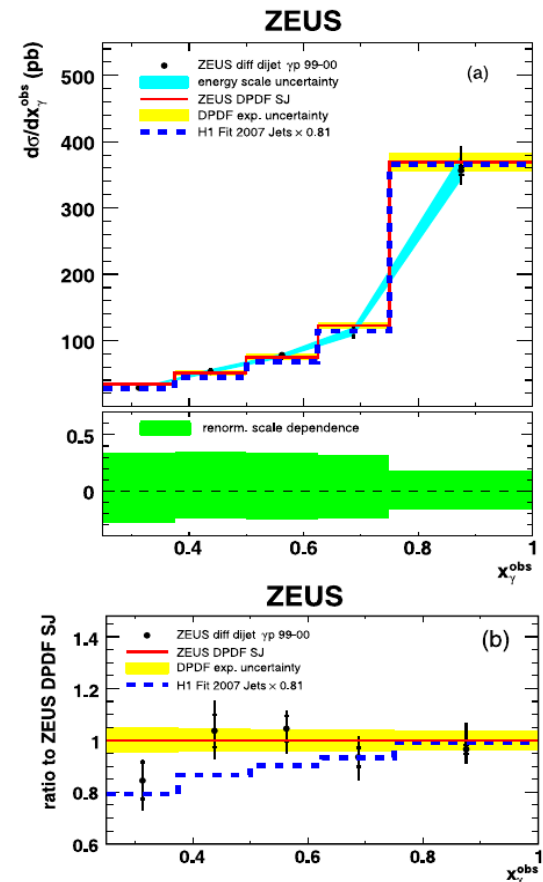

ZEUS results

no suppression observed
 again x_γ independent

Alternative to DPDFs

Recent ZEUS measurement on exclusive dijets

- examination of two-gluon exchange model
- particular difference in ϕ -dependence w.r.t. resolved IP model, where ϕ

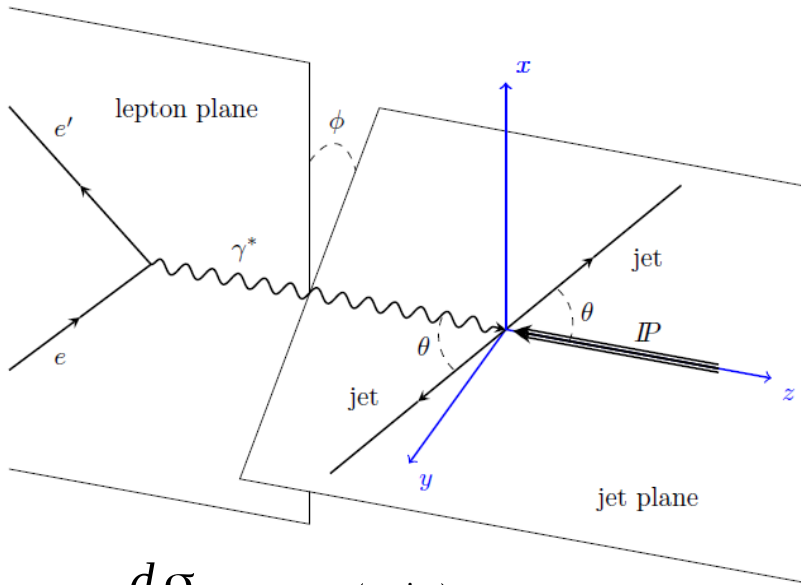
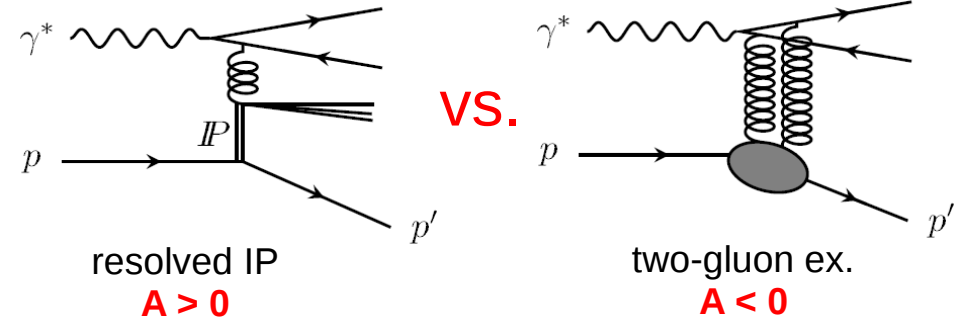

$$\frac{d\sigma}{d\phi} \sim 1 + A(p_T^{jet}) \cos 2\Phi$$

→ normalization off since LO MC is used

ZEUS to be submitted to EPJ

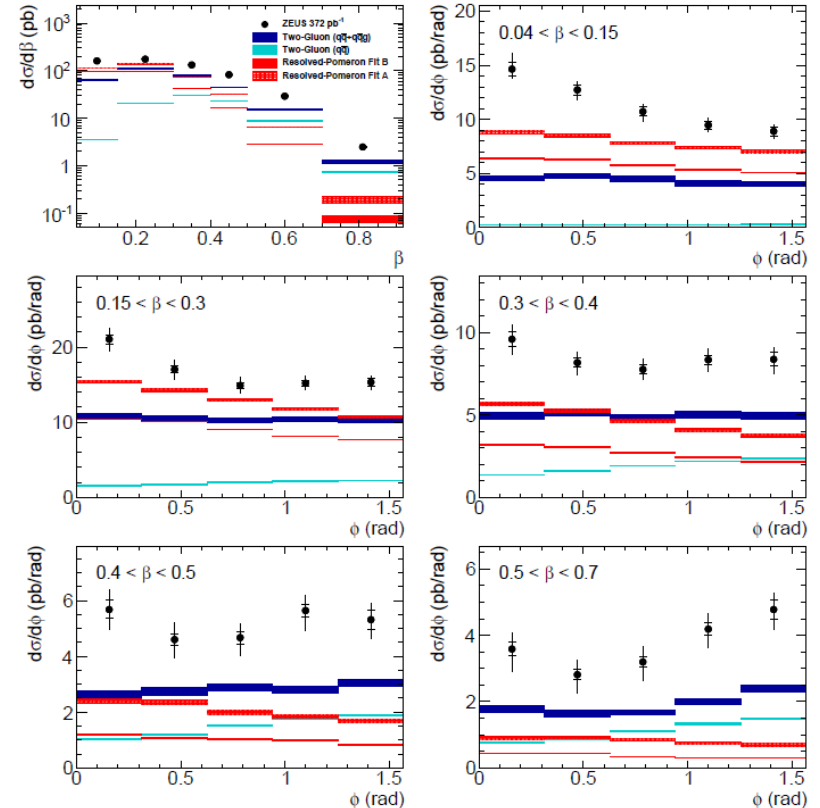

Alternative to DPDFs

Recent ZEUS measurement on exclusive dijets

- examination of two-gluon exchange model
- particular difference in ϕ -dependence w.r.t. resolved IP model, where ϕ

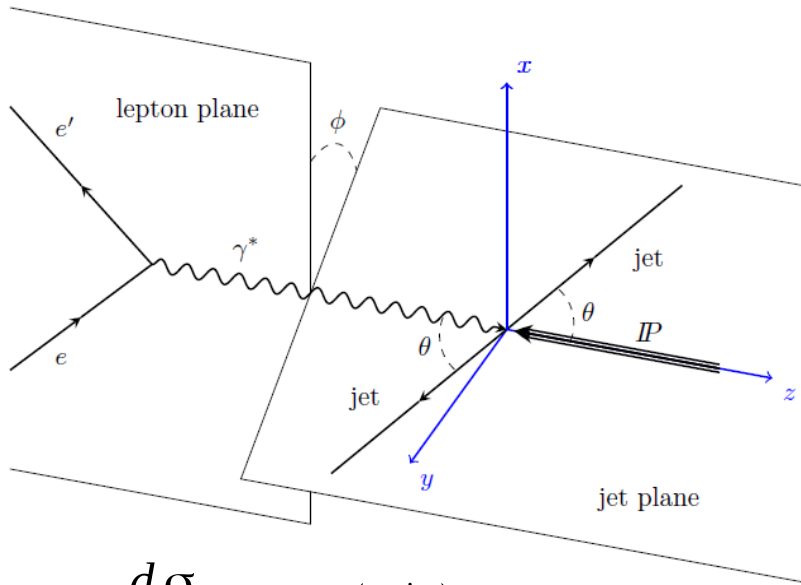

$$\frac{d\sigma}{d\phi} \sim 1 + A(p_T^{jet}) \cos 2\Phi$$

- two-gluon exchange seems to describe the shape parameter better

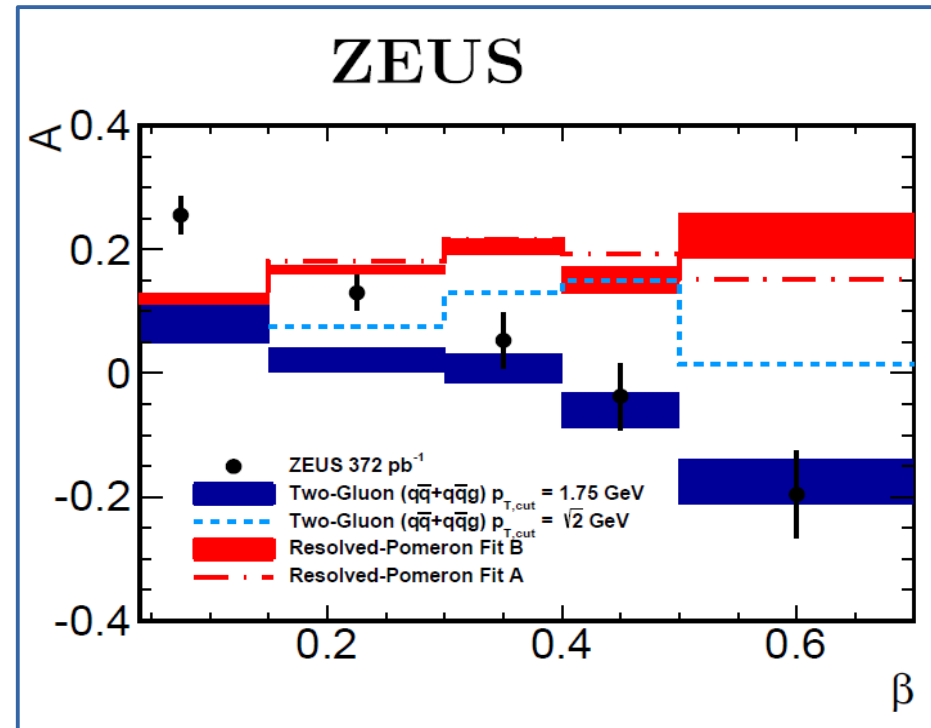
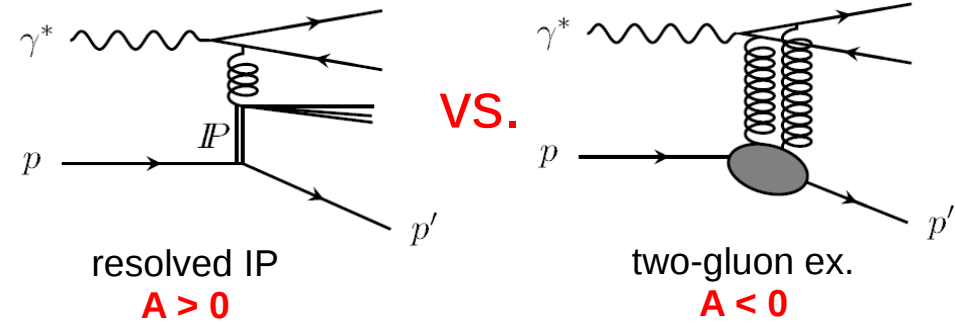

Summary

Diffraction at HERA has been an unexpectedly rich topic

- efficient experimental selection methods developed in H1 and ZEUS
- diffractive processes studies in VM production and DVCS
- large statistics and coverage of DDIS inclusive data allowed DPDFs extraction
- collinear factorization tested for various final states in diffractive γ^* dissociation
- fact. breaking in diffractive dijet photoproduction has not yet been fully understood
- other than DPDF based approaches tested at HERA

... there are many other analyses on diffractive topics from H1 and ZEUS
that have not been covered in this talk