

Photo-production at Trento



charm



Strongly interacting quadrupole
discussing the relevance of color dipoles



beauty



Workshop on Photoproduction at collider energies:

from RHIC and HERA to LHC

ECT* - Trento, Italy, January 15-19, 2007



Hard photoproduction at HERA

S. Levonian, DESY



- HERA and its photoproduction landscape
- General experimental aspects
- Testing QCD with high E_T jets
- Prompt photons as parton level probe
- Charm and beauty
- Summary and Outlook

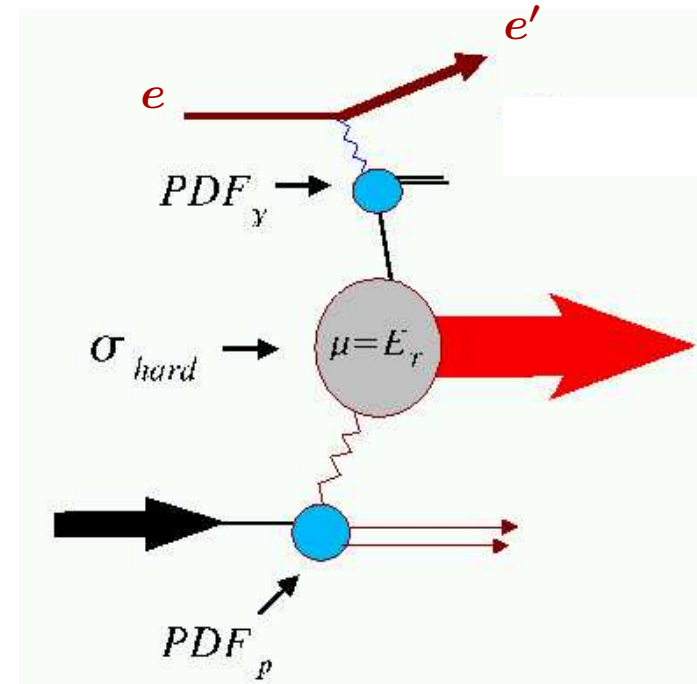

The HERA Collider

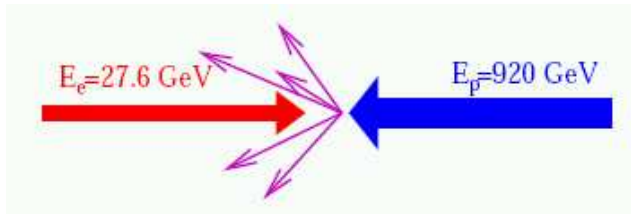
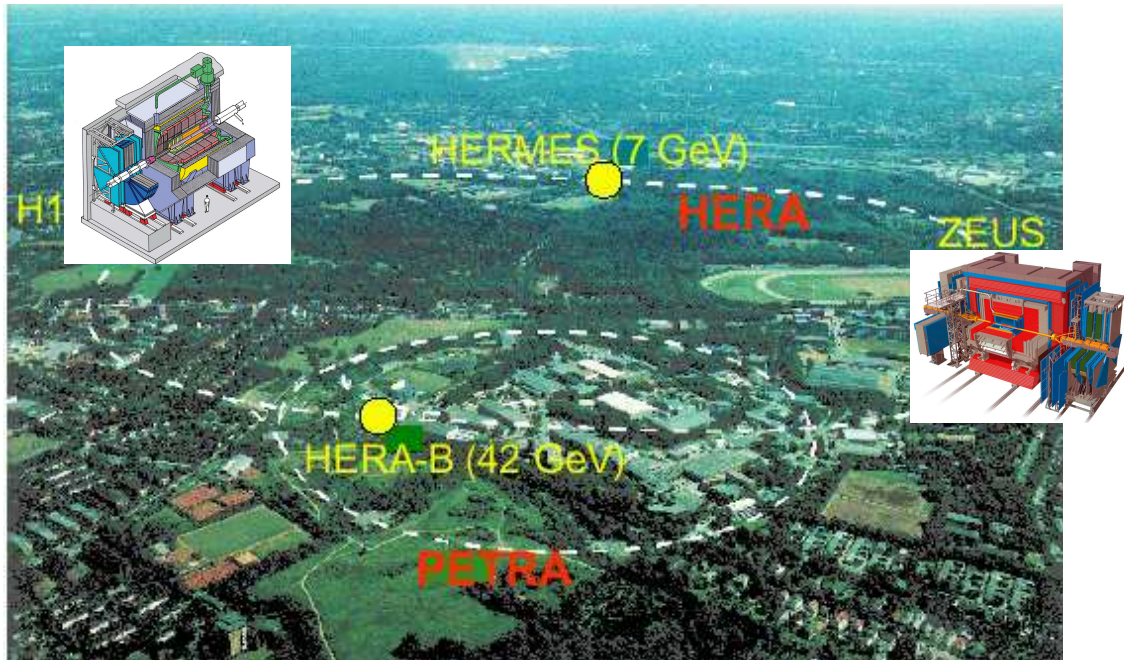

- HERA upgrade emphasizes rare and high p_t processes (Exp. improvements: silicon trackers, triggering, H1-VFPS)
- So far most of published results in photoproduction are based on HERA-1 data \Rightarrow more to come soon

HERA-1 (1993-2000) $\simeq 120 \text{ pb}^{-1}$

HERA-2 (2003-2007) $\simeq 380 \text{ pb}^{-1}$

last 3 months - low E_p run to measure F_L^p
($E_p = 460 \text{ GeV}$, $\mathcal{L} \simeq 10 - 15 \text{ pb}^{-1}$)

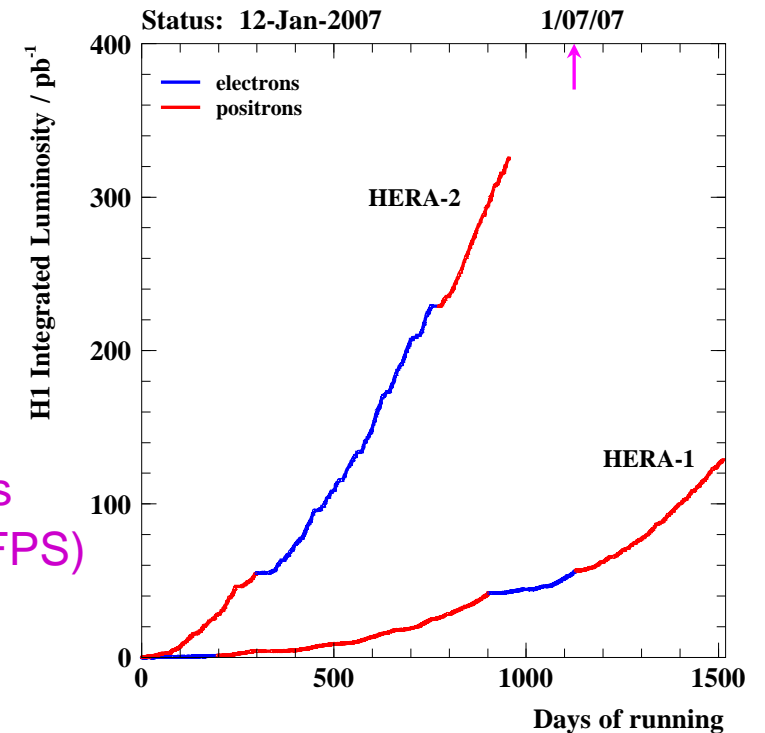

Photoproduction Landscape at HERA

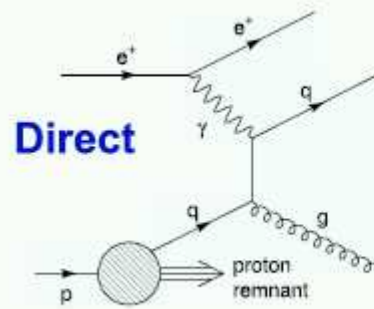

Direct

$\cos \theta^*$

$$x_\gamma = 1$$

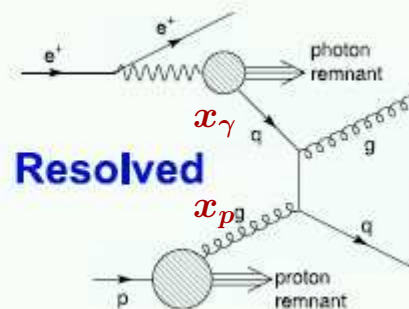

Resolved

$$x_\gamma < 1$$

$$x_\gamma = \frac{1}{2yE_e} \sum_i E_{t,i} e^{-\eta_i}$$

$$x_p = \frac{1}{2E_p} \sum_i E_{t,i} e^{+\eta_i}$$

$$\cos \theta^* = \tanh\left(\frac{\eta_1 - \eta_2}{2}\right)$$

Beyond LO this classification becomes ambiguous

Soft γp

σ_{tot} , min.bias events (E-flow, multiplicity), light VM

Hard γp

inclusive jets → high E_t tail, scaling violation, α_s
 dijets → probing gluons in the proton and photon
 multijets → NNLO effects, MPI, colour dynamics
 prompt photons → "direct" probe at parton level (no hadronisation effects)
 heavy quarks → parton evolution dynamics; note multiscale problem (m_Q, E_t, Q^2)

Hard-soft interplay

Diffraction and its factorisation properties
 Soft vs hard IP , Multiple int., LRG survival

*see talks by A. Valkarova
and A. Savin*

HERA specifics:

transition from $Q^2 = 0$ to $Q^2 \geq 10 \text{ GeV}^2$ (virtual photon structure etc.)

Experimental Aspects

- Selecting photoproduction:

- ▷ tagged γp ($Q^2 < 0.01 \text{ GeV}^2$, $0.3 < y < 0.7$) – clean, but limited in statistics and W range
- ▷ untagged γp ($Q^2 < 1 \text{ GeV}^2$) – no scattered e observed in the detector

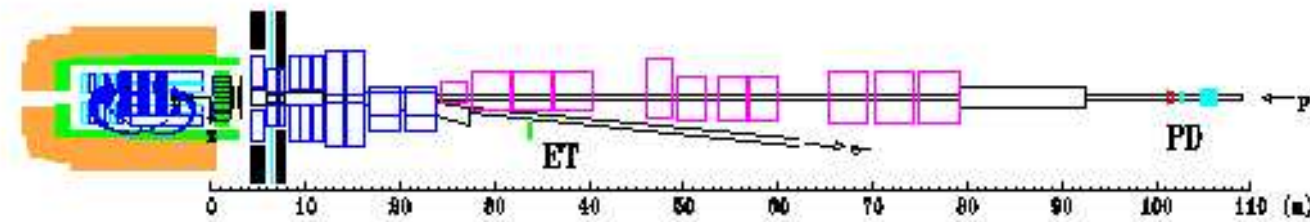

$$y = E_\gamma / E_e$$

- $ep \rightarrow \gamma p$ cross section: use WWA for photon flux $f_{\gamma/e}(y, Q^2)$
- Direct/resolved γp separation: $x_\gamma^{obs} > < 0.75(0.8)$
- Experimental signatures
 - ▷ jets (mainly inclusive k_t , occasionally cone algorithms)
 - ▷ isolated high E_t photons
 - ▷ HQ (tagged by D^* , μ decay, life time technique)
- Dominant experimental/theoretical uncertainties:
 - ▷ Jet E -scale: (3 – 4)% at 5 GeV (1 – 1.5)% at 20 GeV \Rightarrow (20 \rightarrow 7)% in σ_{jets}
 - ▷ hadronisation, non-pert. effects (model dependence) \sim (5 – 10)% depending on typical E_T
 - ▷ theory: scale dependence due to missing HO terms ($\mu_r, \mu_f \cdot (1/2 - 2)$) \Rightarrow (5 – 20)%

Correcting for additional energy from soft underlying event

min.bias and medium E_T γp samples

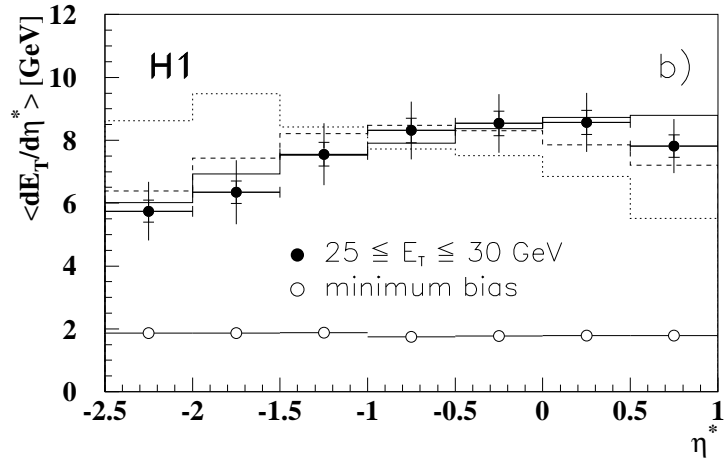
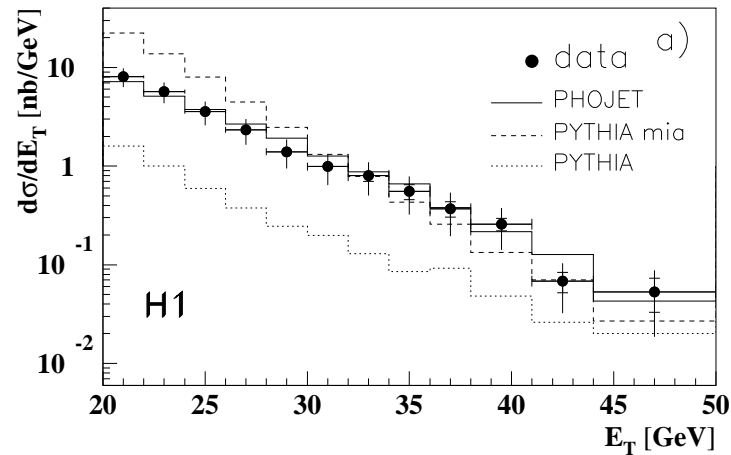

high E_T dijet sample ($E_{T,\max} > 25$ GeV)

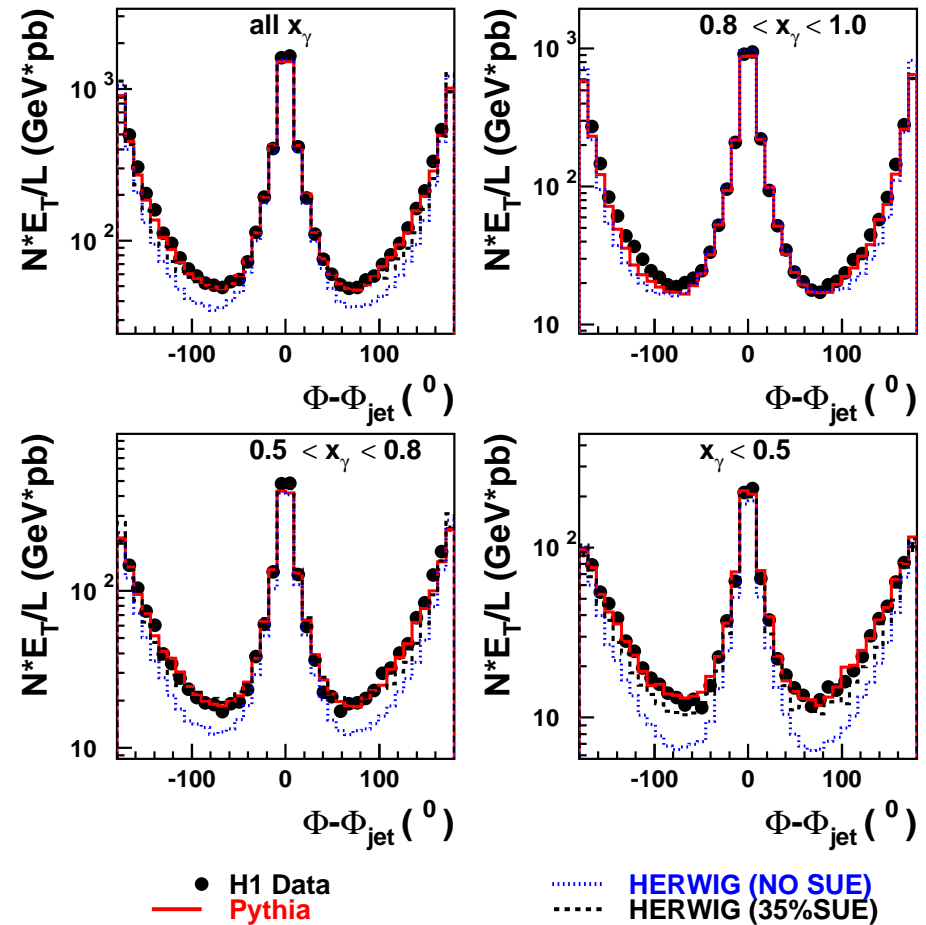

★ After tuning MC parameters Jet profiles and E -flow are fairly well described

MC models

All available MC programs have LO ME + PS for hard QCD processes.
They differ in parton evolution schemes and in modelling fragmentation:

- PYTHIA

- ▷ Collinear factorisation, DGLAP evolution equations
- ▷ LUND string fragmentation model
- ▷ multiple interaction between photon and proton remnants (LO QCD proc. with small $p_t^{cut} \simeq 1.2$ GeV)

- HERWIG

- ▷ Collinear factorisation, DGLAP evolution equations
- ▷ cluster hadronisation model
- ▷ SUE (parametrized soft hh collisions) with tunable probability ($P1 = 35\%$ for HERA)

- PHOJET

- ▷ Collinear factorisation, DGLAP evolution equations
- ▷ two-component Dual Parton model using unitarization scheme based upon AGK cutting rules
- ▷ LUND string fragmentation model
- ▷ multiparton interactions are naturally included (from multi- \mathbf{P} contributions)

- CASCADE

- ▷ k_t factorisation, CCFM evolution scheme, unintegrated parton densities $f_{q,g}(x, k_t)$
- ▷ only gluon induced processes (emphasis on low x phenomena, HQ) quark contributions still missing
- ▷ Interfaced to Pythia/Jetset for use of LUND string fragmentation model

$\mathcal{O}(\alpha\alpha_s^2)$ QCD calculations

■ Jets

- Frixione and Ridolfi (1997) – subtraction method to deal with infrared singularities
- Klasen, Kramer, Kleinwort (1998) – phase space slicing technique

Typical parameter set: 5 flavours, $\alpha_s(M_Z) = 0.118$, $\mu = \mu_f = \mu_r = \mu_\gamma = \mu_p = E_T^{jet}$
 proton PDFs: CTEQ5M, MRST99 photon PDFs: GRV-HO, AFG-HO

■ Prompt γ

- Krawczyk and Zembrinsky (KZ) (2001,2003)
- Fontannaz, Guillet, Heinrich (FGH) (2001,2004)
 collinear factorisation, DGLAP evolution (some differences in HO terms for resolved component)
- Lipatov, Zotov (LZ) (2005)
 k_t factorisation approach, using unintegrated parton densities

■ HQ

- FMNR (1995) – massive scheme, Peterson fragmentation for charm
- ZMVFNS(2003) – massless scheme, BKK fragmentation
- GMVFNS(2005) – combined massive and massless scheme, KKSS fragmentation

Jets in PHP: Overview

• Inclusive jets:

- highest statistics,
- least restrictive (largest phase space),
- theoretically most "safe"

$$\sigma_{Jet} = flux(y, Q^2) \times PDF_\gamma \times PDF_p \times \sigma_{hard}$$

• Dijets:

- good reconstruction of hard scattering kinematics,
- sensitivity to proton and photon PDFs as well as to the basic properties of ME
- some care needed to avoid infrared unsafe regions (asymmetric jet E_T cuts)

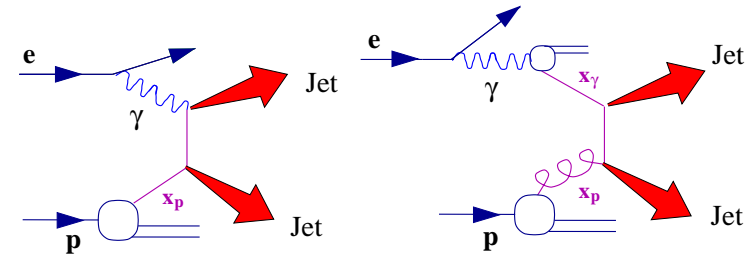

• Multijets:

- access to higher orders of pQCD,
- details of parton evolution,
- multi-parton interactions (MPI),
- underlying gauge group properties
- ...

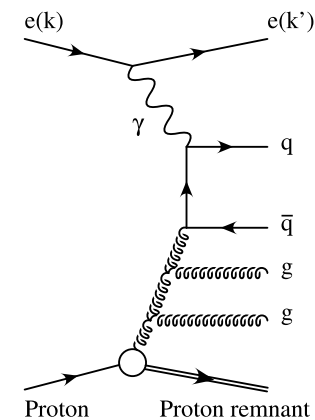

Inclusive jets vs NLO QCD

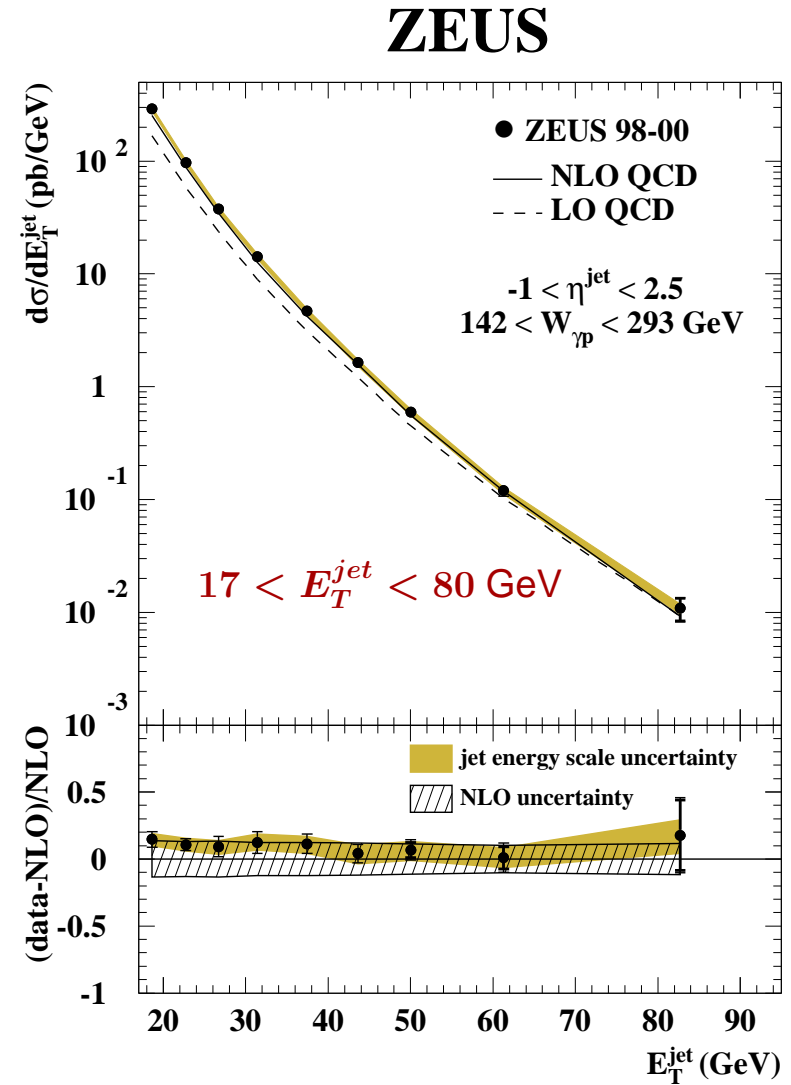
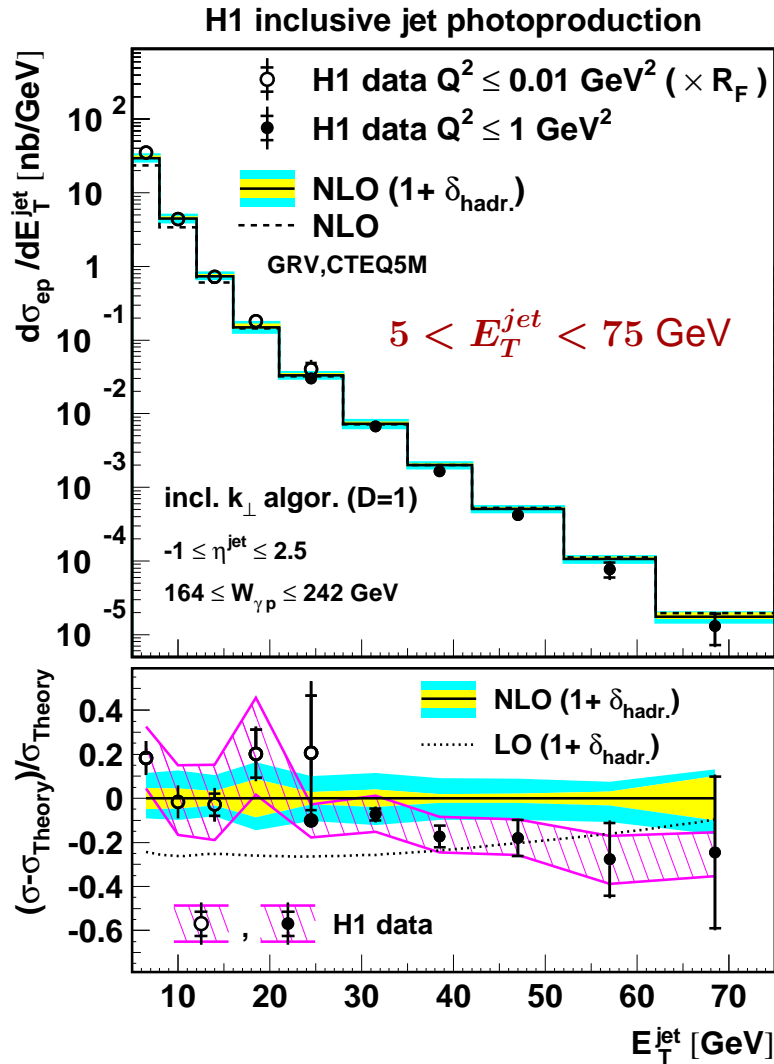

★ Good agreement with NLO over 6 orders of magnitude. Dominant uncertainty due to theory

Inclusive jets vs NLO

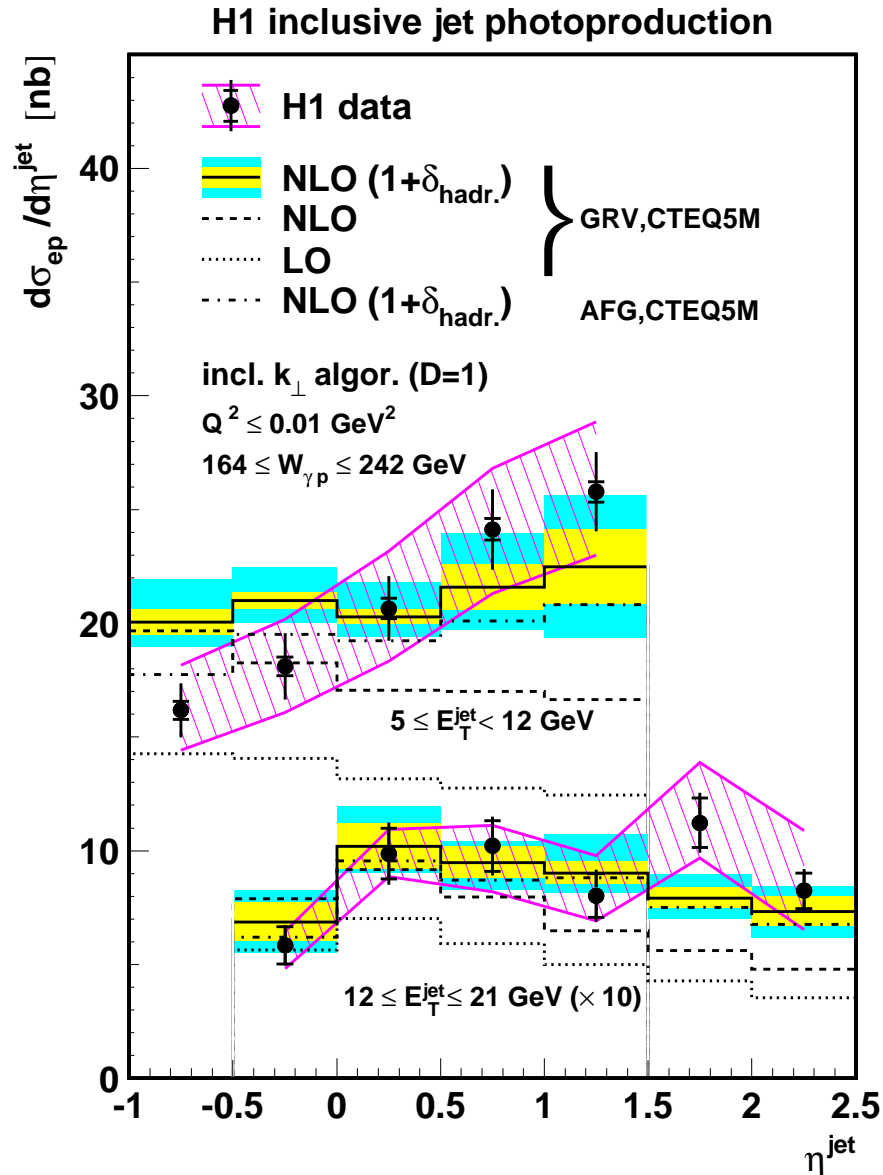

- NLO is OK in high E_T range, but provides only marginal agreement for low E_T^{jet}
- Low E_T range is challenging:
 - hadronisation corrections and underlying event energy become substantial, in particular in forward range (large η , low x_{γ})
 - Failure of LO MC to accurately estimate those?
 - Problems in photon PDFs in this kin.range?
 - Absence of HO terms beyond NLO? (Large NLO/LO corrections indicate this)

Inclusive jets: Scaling violation

$$x_T = 2E_T^{jet} / W_{\gamma p}$$

- naive parton model predicts that scaled cross section $(E_T^j)^3 d^3\sigma / d^3p_j$ is independent on $W_{\gamma p}$

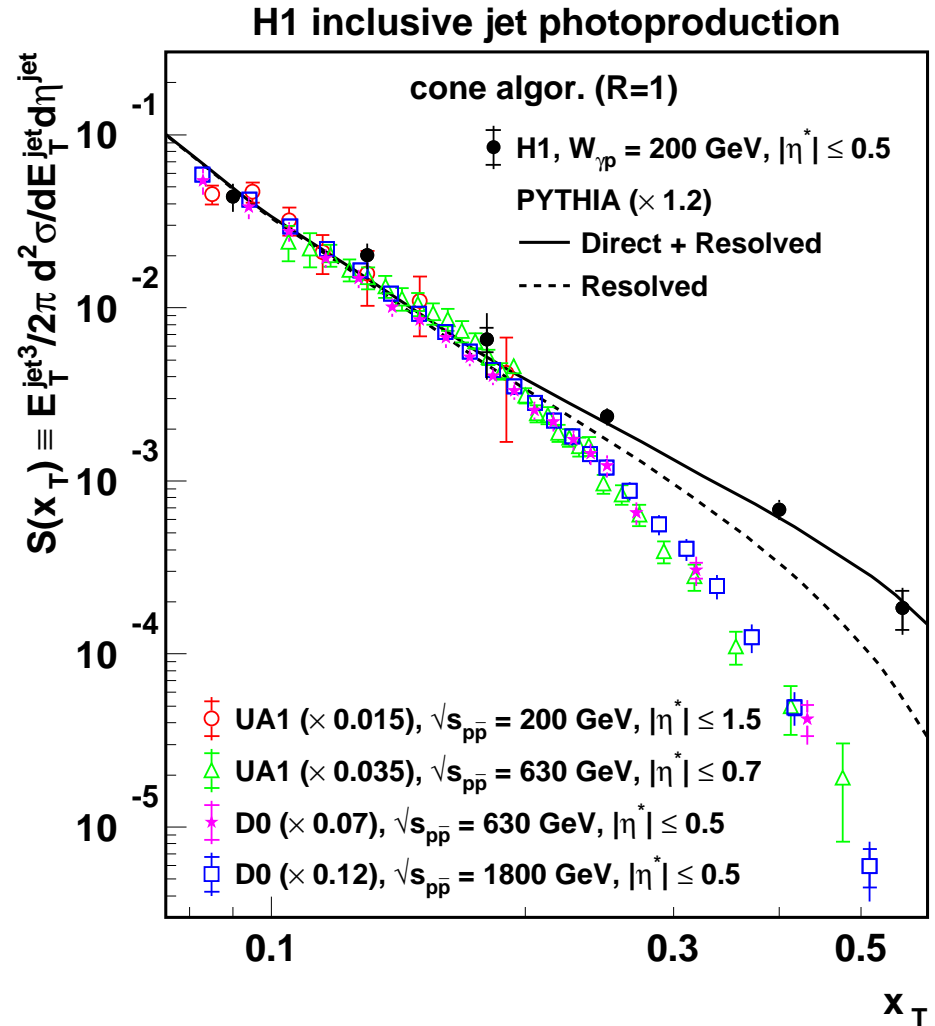
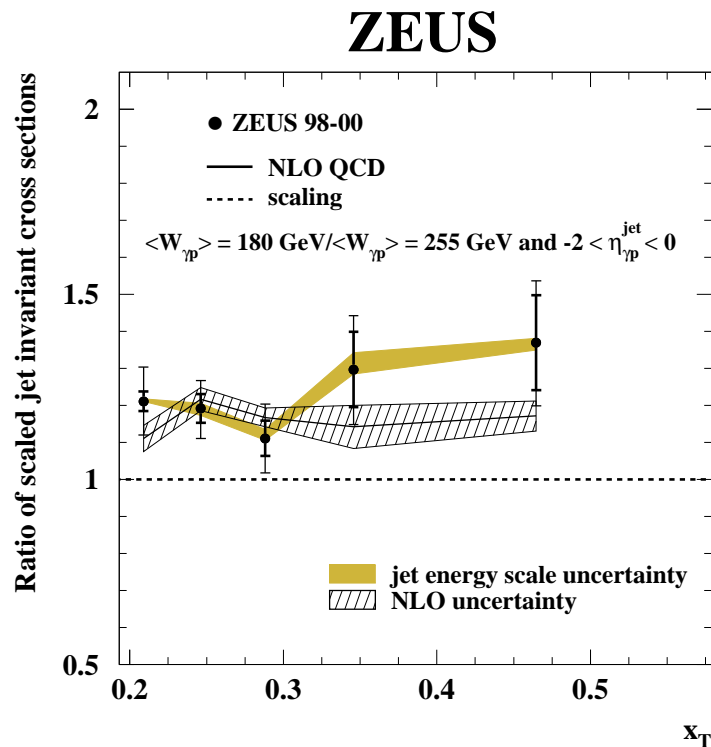

★ Clear scaling violation is observed, in agreement with NLO QCD expectations

★ At $x_T < 0.2$ γp is similar to $\bar{p}p$, while at higher x_T the shape is different, reflecting difference in p and γ PDFs as well as direct γp contribution

Inclusive jets: Extracting α_s from scaling violation

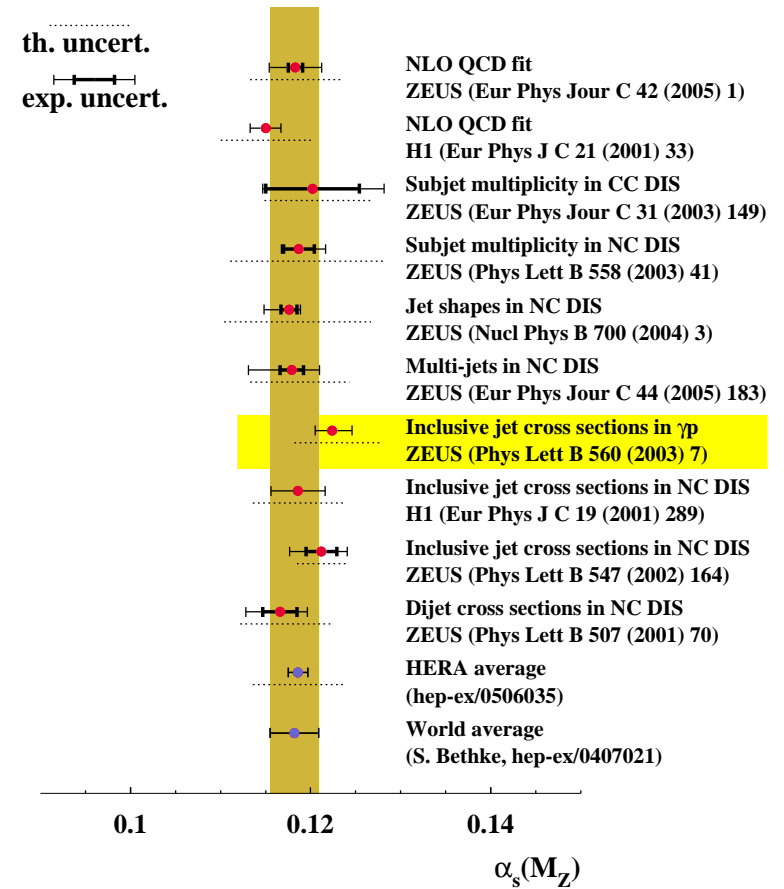
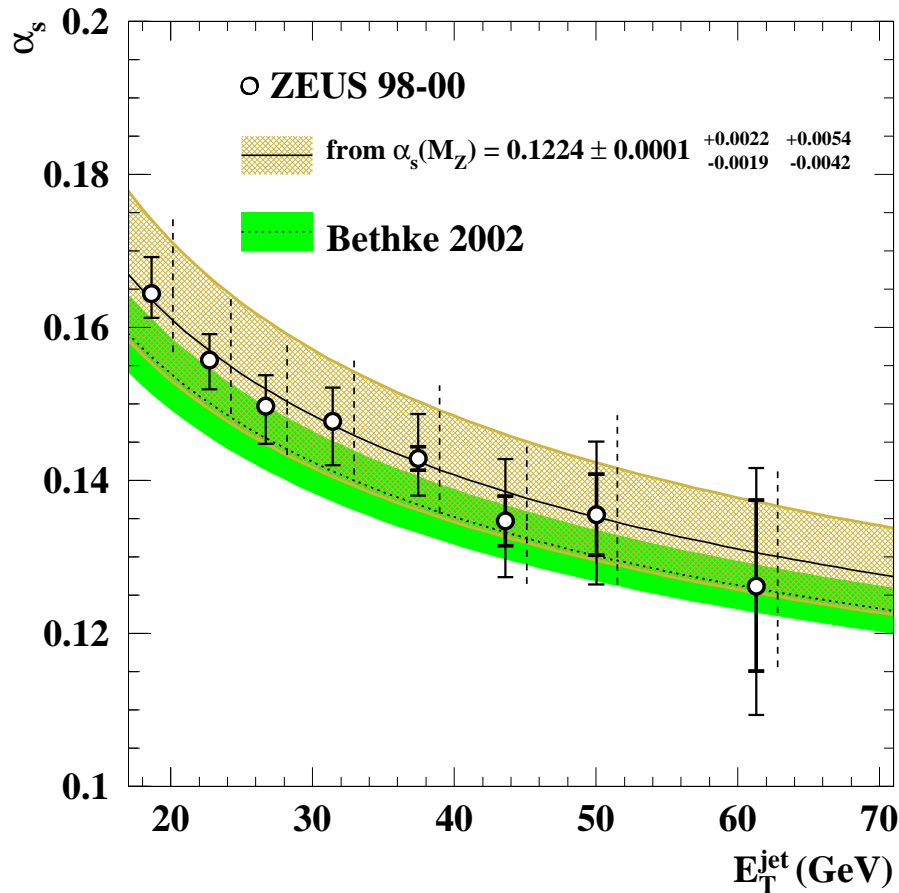

$$d\sigma/dE_T^{\text{jet}}(\alpha_s(\mu)) = C_1\alpha_s(\mu) + C_2\alpha_s(\mu)^2$$

- ★ Competitive measurement of α_s consistent with other methods and world average
- Dominating error comes from missing HO terms beyond NLO (scale uncertainty)

Dijets: Motivation

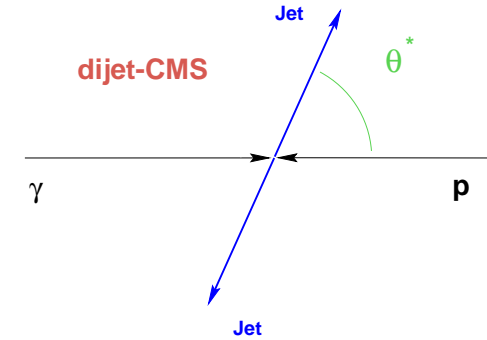
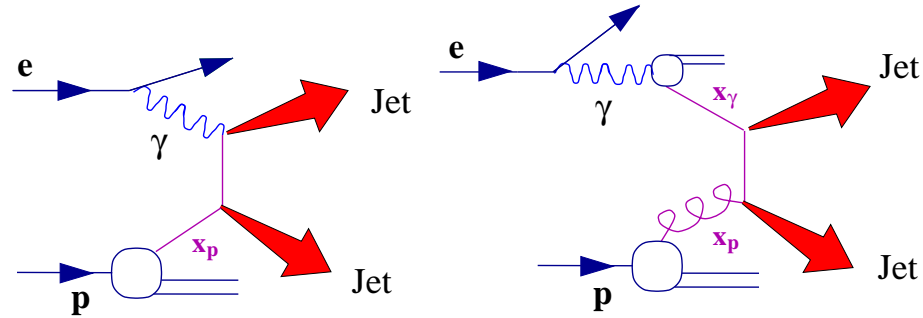

with 2 high E_T jets kinematics of hard scattering is fully defined

- x_γ dependence: sensitivity to photon structure
- x_p dependence: sensitivity to photon structure (esp. gluon at large x_p)
- $\cos \theta^*$ dependence: sensitivity to short distance dynamics

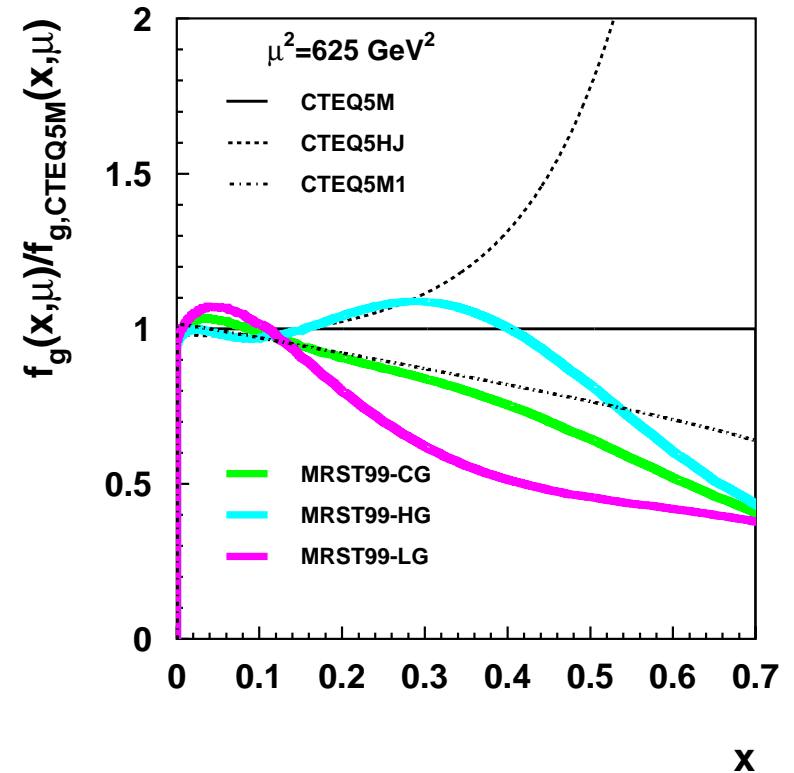

Dijets: Photon structure at LO

- $E_T^{jet} > 6$ GeV (trying to access low x_γ) \Rightarrow large non-pert. effects \Rightarrow LO analysis only
- High p_t charged particles ($p_t > 2.6$ GeV/c) \Rightarrow completely different systematics \Rightarrow complementary method
- Gluon is obtained by subtracting quarks from effective pdf $[q(x_\gamma) + \bar{q}(x_\gamma) + \frac{9}{4}g(x_\gamma)]$ unfolded from x_γ^{obs}

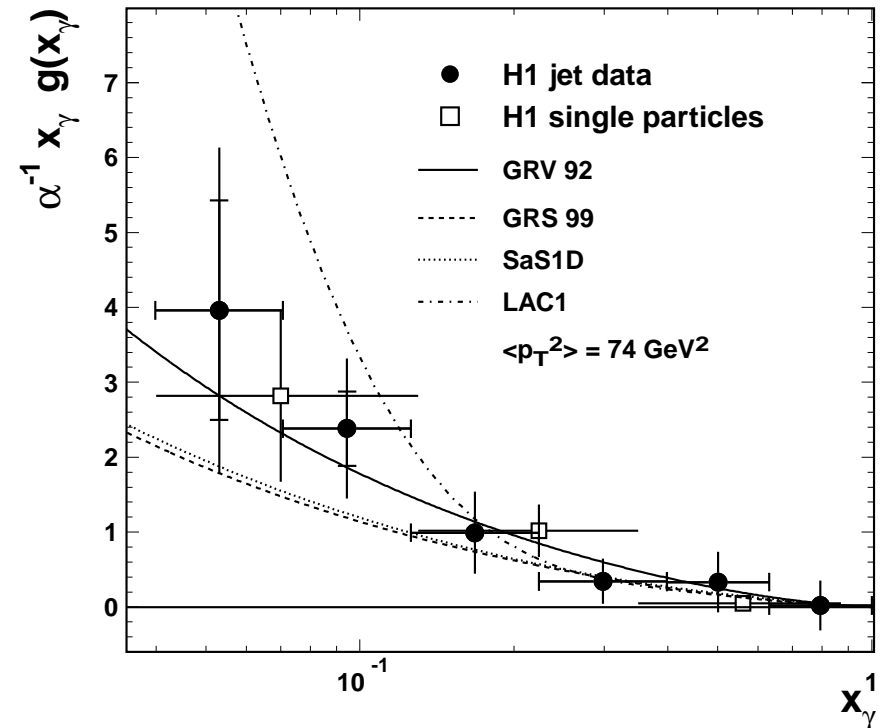
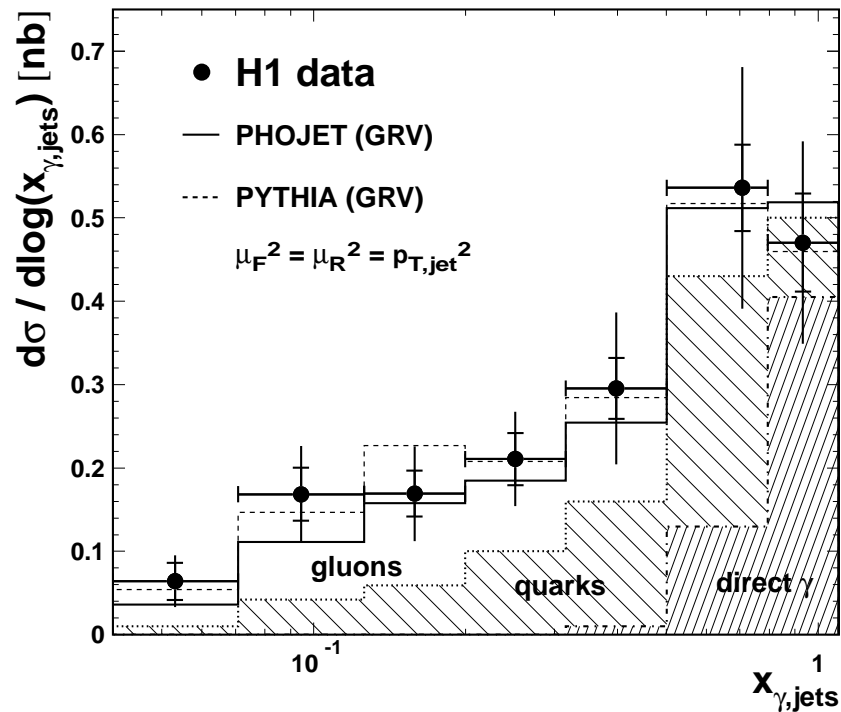

★ So far this is the only extraction of gluon in photon (although in LO)

Is it worth to repeat exercise with 50 fold statistics and NLO analysis?

Dijets: Photon structure at NLO

- The price for higher E_T^{jet} is that only relatively large $x_\gamma > 0.1$ can be probed ($x_\gamma = \frac{E_T^{j1} e^{-\eta_{j1}} + E_T^{j2} e^{-\eta_{j2}}}{2yE_e}$)
- NLO analysis: Theoretical scale uncertainty dominates over experimental errors

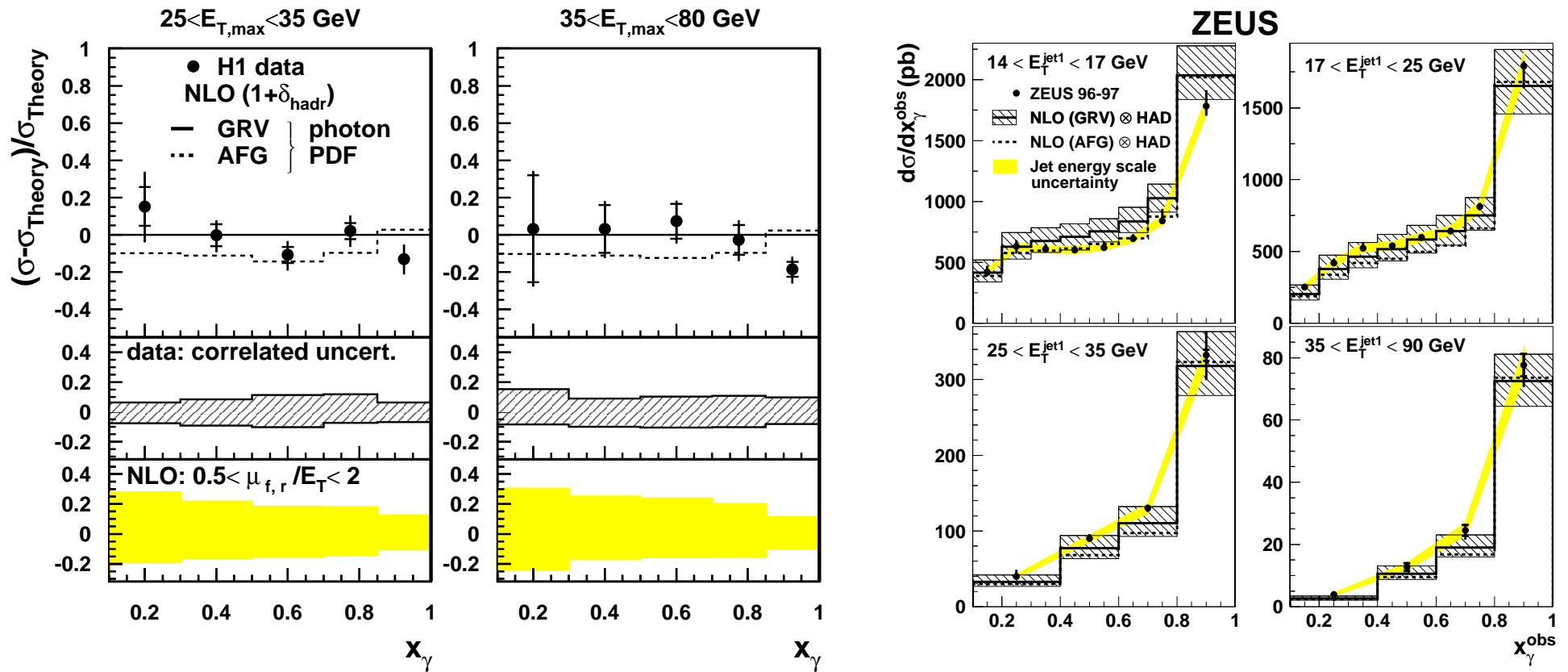

★ Probe photon PDFs at much higher scales than ever before (up to 8000 GeV²)

★ Within $\sim 15\%$ present γ -PDFs are OK, but the data show potential to further constrain them

Dijets: x_p dependence

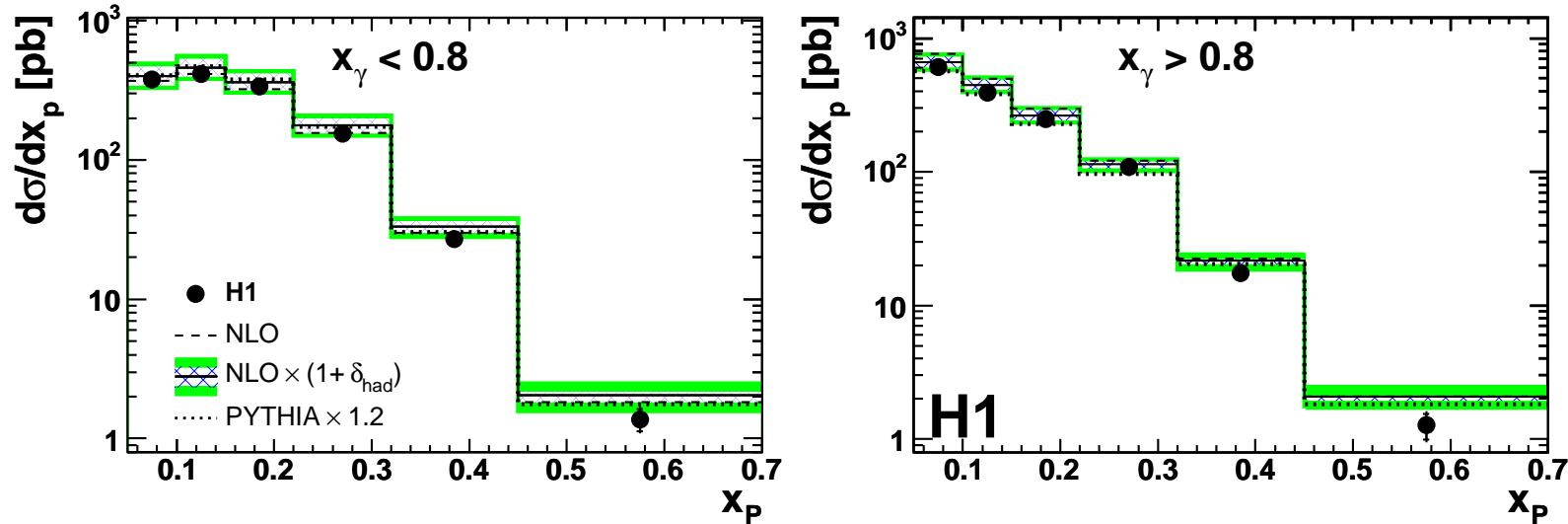

- $E_T^{jet_1} > 25$ GeV, $E_T^{jet_2} > 15$ GeV
- LO MC is off by 20%(Pythia) or 55%(Herwig) at low x_p NLO agrees with data within 10%
- CTEQ5M–MRST $< 5\%$ at $x_p < 0.1$ and $\sim 15\%$ at $x_p > 0.1$ at $x_p \simeq 0.1 \approx 35\%$ of the cross section is gluon induced

⇒ Data are sensitive to high x_p gluon in the proton and can be used in the global fits (e.g. ZEUS: hep-ph/0503274) ⇒

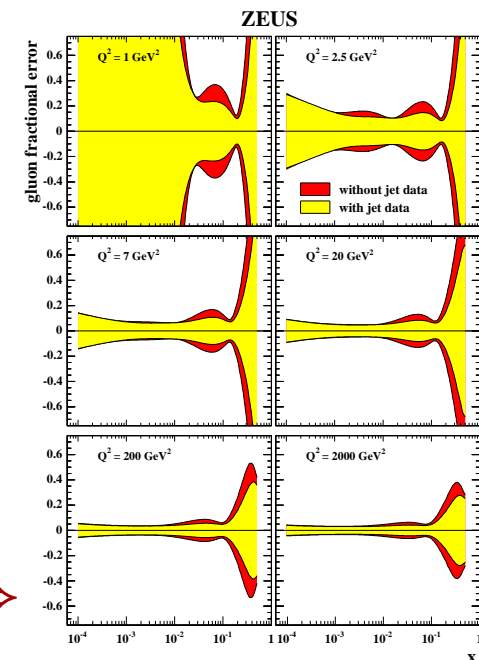

Dijets: $|\cos \theta^*|$ dependence

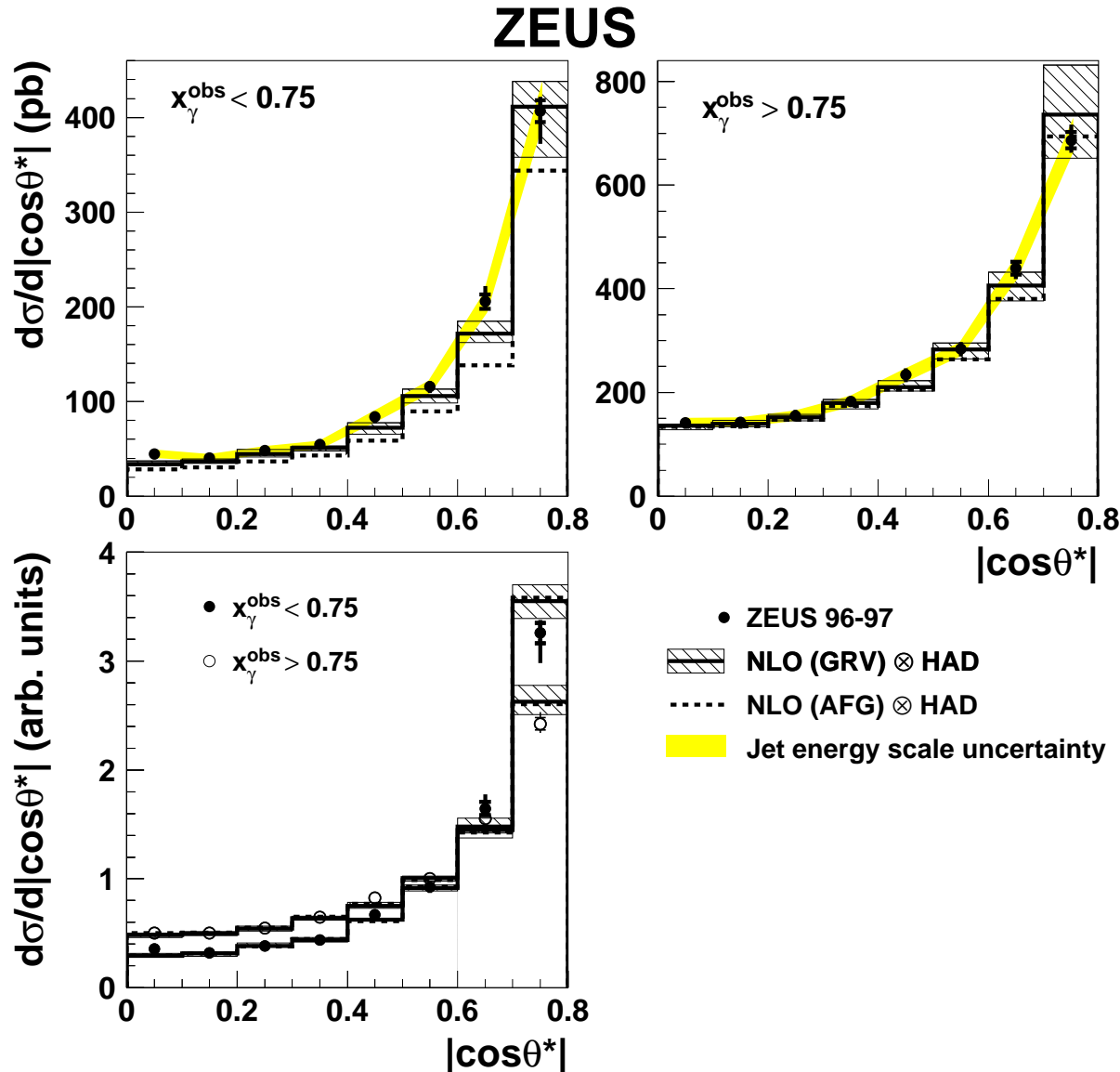

$$E_T^{\text{jet}1} > 14 \text{ GeV},$$

$$E_T^{\text{jet}2} > 11 \text{ GeV},$$

$$M_{JJ} > 42 \text{ GeV}$$

- NLO calculation is able to describe angular dependence

- Shapes are consistent with expectations from dominant propagators:

$$\text{"gluon"} \propto (1 - |\cos \theta^*|)^{-2}$$

$$\text{"quark"} \propto (1 - |\cos \theta^*|)^{-1}$$

Multijets in PHP: New largely unexplored field

access to
HO QCD

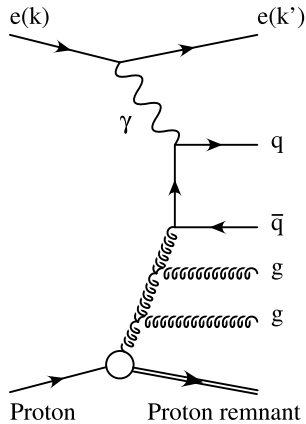

4 jets

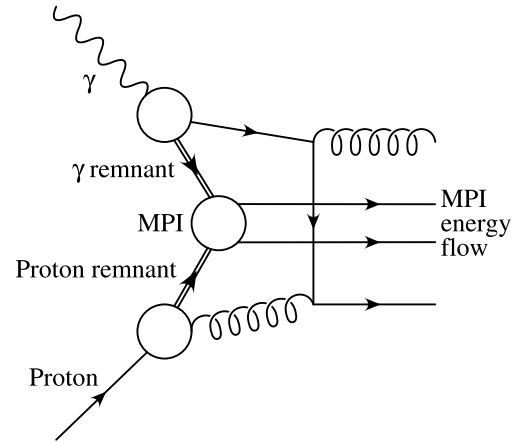

impact on LHC
(LRG survival)

LO is $\mathcal{O}(\alpha\alpha_s^3)$ – no calculations exist

Example of MPI producing 4-jet final state

(see in the talk by **A.Savin**)

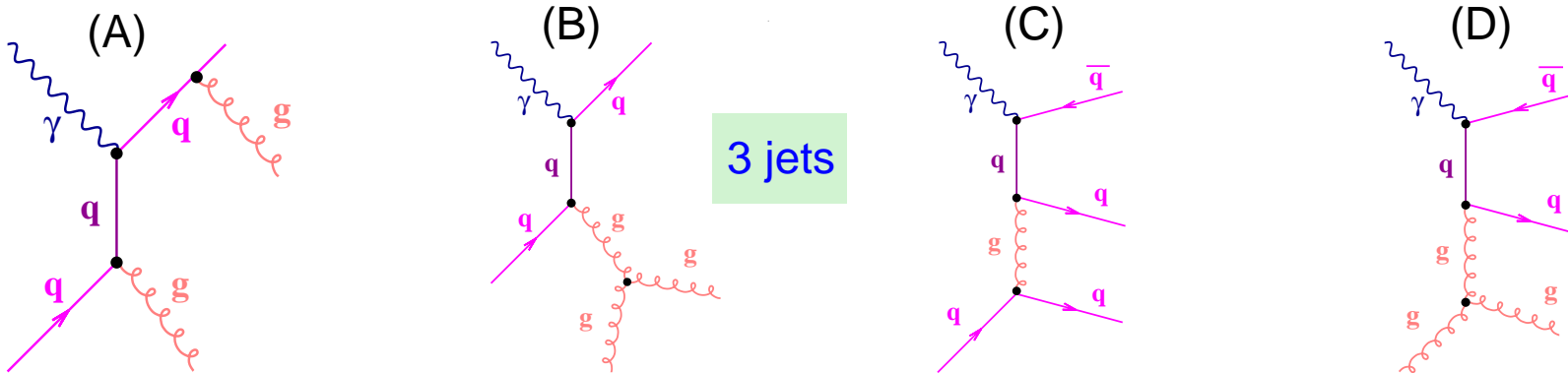

3 jets

$$\text{LO: } \sigma_{ep \rightarrow 3j} = C_F^2 \sigma_A + C_F C_A \sigma_B + C_F T_F \sigma_C + T_F C_A \sigma_D$$

sensitivity to the underlying gauge group structure

Multijets: Colour dynamics with 3-jet events

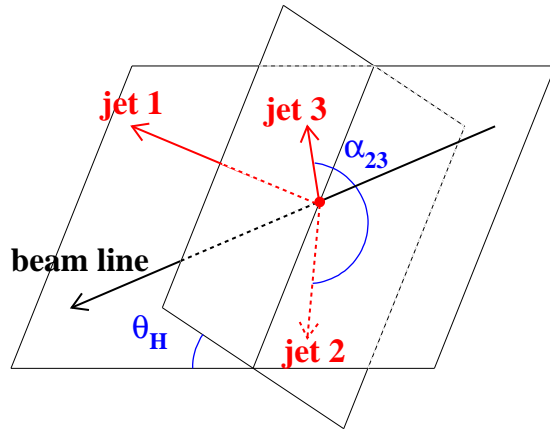

Study the angular dependencies of normalized cross sections, selecting direct enriched sample:

shapes of different terms
sensitive to colour configurations

Data:

2233 3-jet events

$E_T^{jet} > 14$ GeV each

$-1 < \eta^{jet} < 2.5$, $x_\gamma^{obs} > 0.7$

$\mathcal{O}(\alpha_s^2)$ calculation

$\alpha_s(M_Z) = 0.1175$

$\mu_r = \mu_f = E_T^{max}$

Hadr.corr. from Pythia

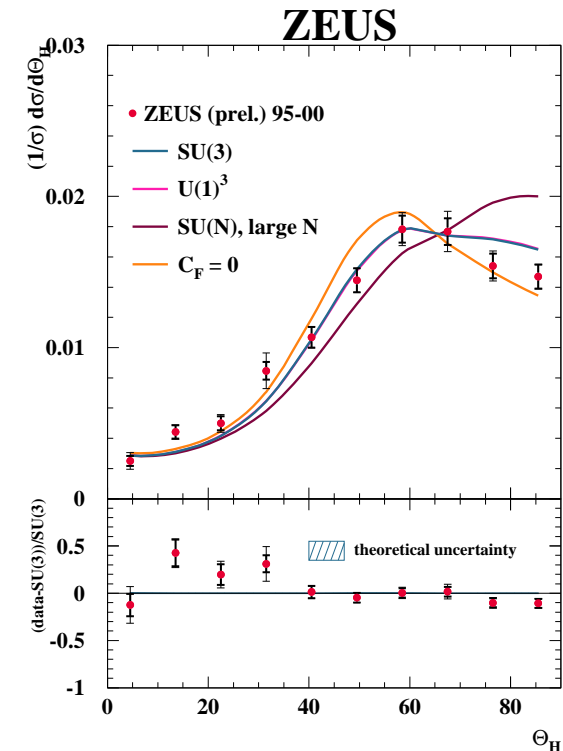
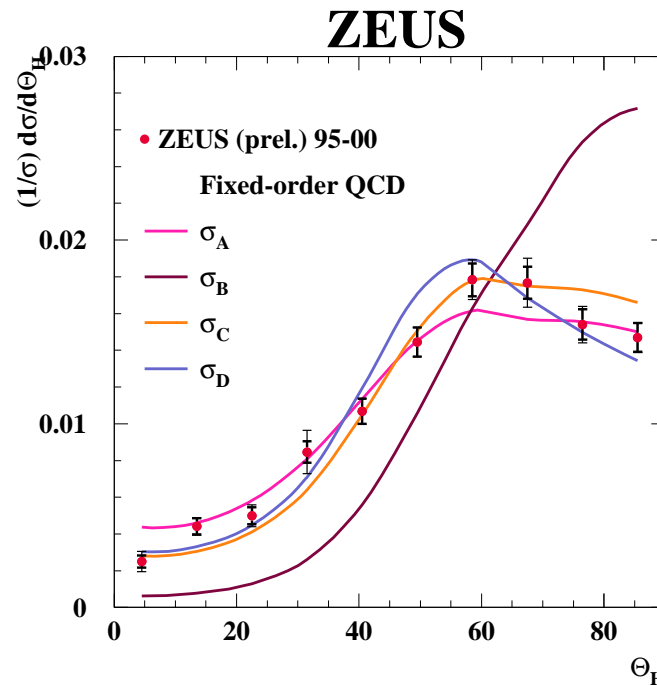

★ Data are consistent with $SU(3)$ colour 'mixture'

3-jet data vs $\mathcal{O}(\alpha\alpha_s^2)$ pQCD

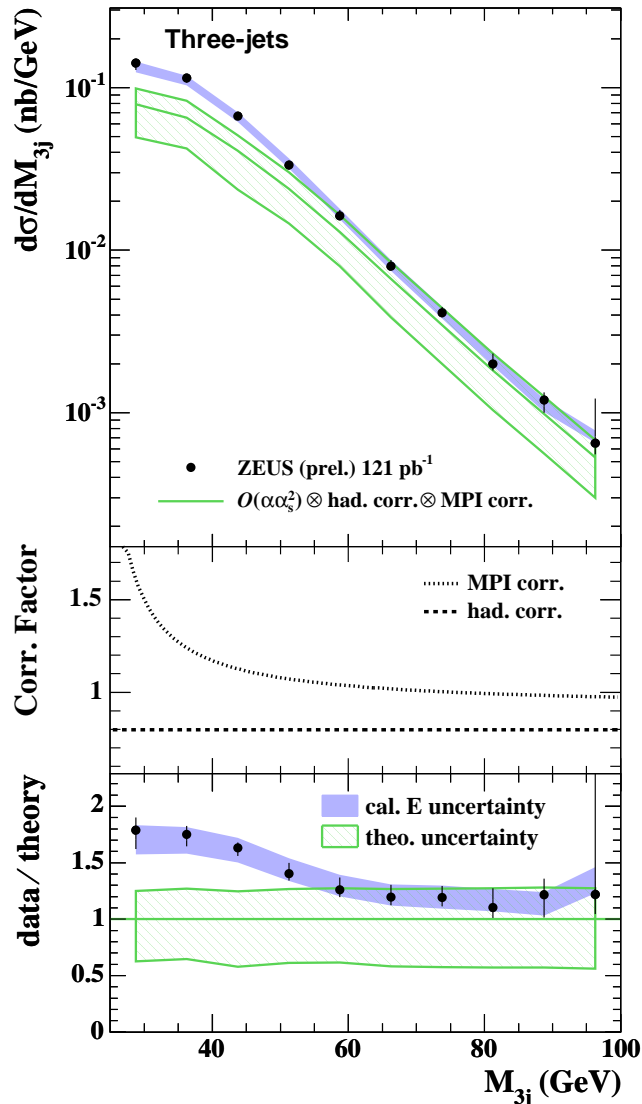

- **Data:** $Q^2 < 1 \text{ GeV}^2$, $142 < W_{\gamma p} < 293 \text{ GeV}$
 $E_T^j > 7, 7, 5 \text{ GeV}$, $|\eta^j| < 2.4$, $M_{3j} > 25 \text{ GeV}$
- **Theory:** $\mathcal{O}(\alpha\alpha_s^2)$ calculation by
 by M.Klasen, T.Kleinwort and G.Kramer (1998)
- **Non-perturbative effects:**
 - hadronization corrections reduce σ_{3j} by $\mathcal{O}(20\%)$
 - mult.int. from HERWIG-JIMMY eikonal model
 (only essential in low mass region, $< 50\text{GeV}$)
- **Theoretical uncertainty is large, as expected from LO calculation**
- **At high M_{3j} calculations are in rough agreement with the data, but significantly underestimate low mass cross section**

Prompt photons

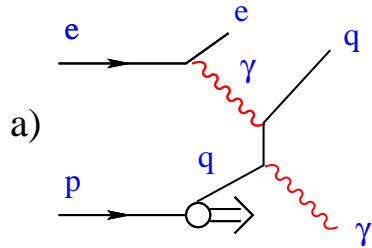

Direct γp production

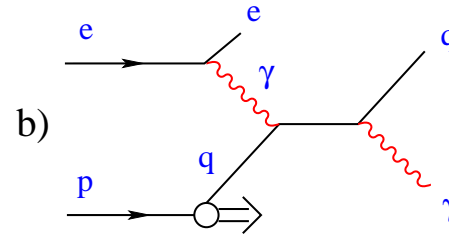

Resolved γp production

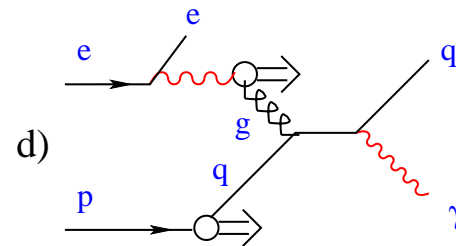
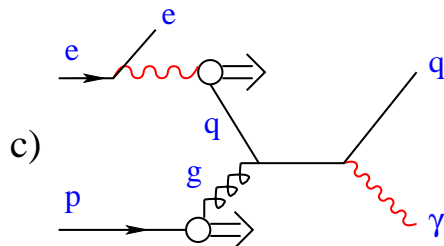

γ signature:

isolated e.m. cluster

γ +jet signature:

jet balancing γ in p_t

+ free of hadronisation effects \Rightarrow
direct link to parton level

— low statistics as compared to jets

smaller experimental E-scale uncertainty
(e.m. scale is better known than hadronic)

difficult background from π^0/η decays
(dominant systematics, $\approx 10-20\%$)

- Previous measurements have shown that inclusive production of prompt photons in hadron-hadron and γ -hadron collisions is unexpectedly large. Why?

Prompt photons: Signal extraction

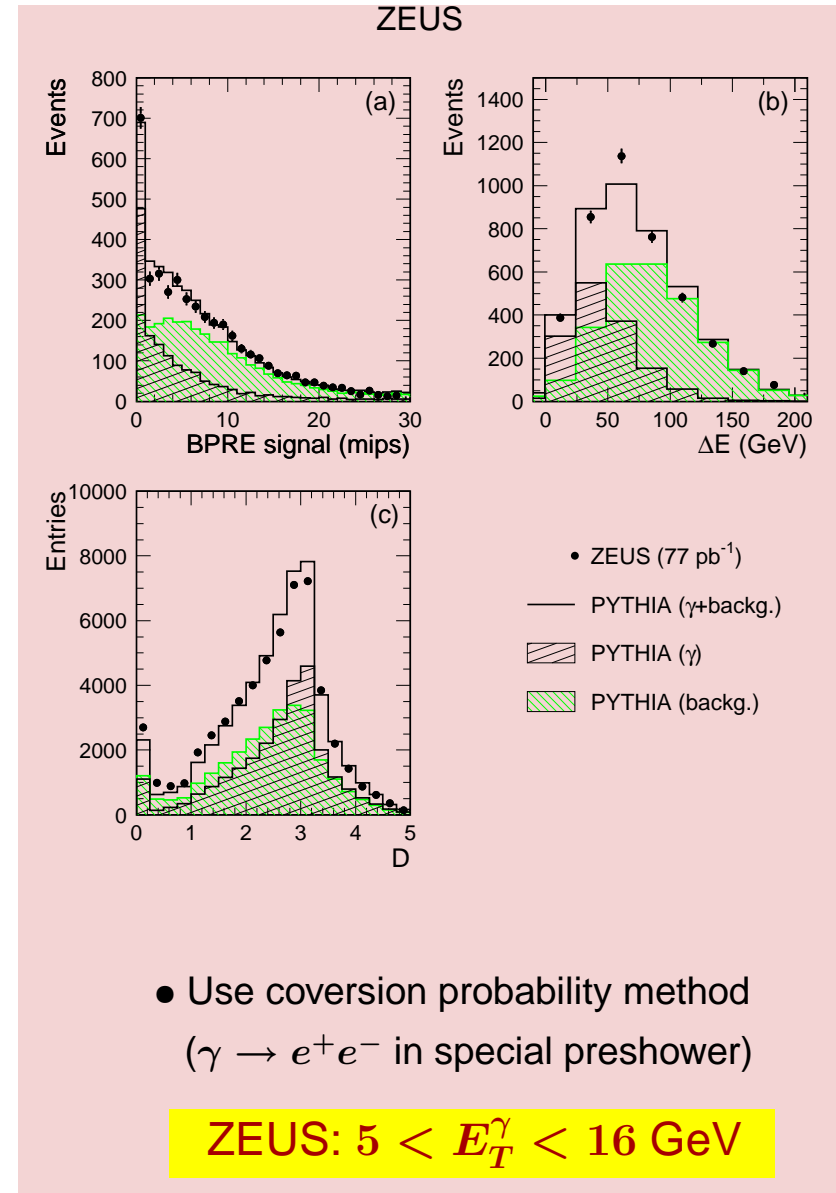
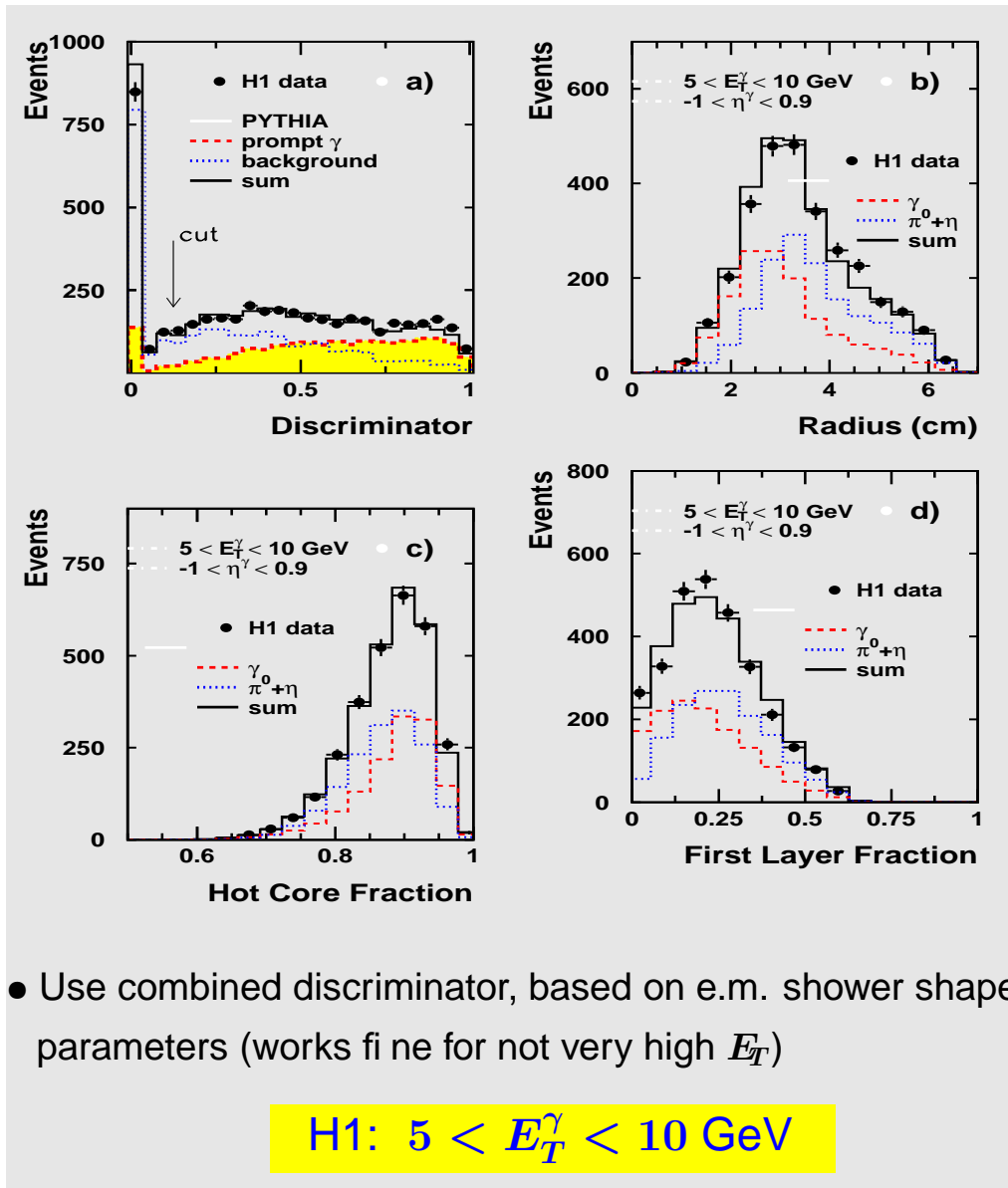

- Purity of the final sample is $\sim 50\%$ Remaining background is subtracted statistically

Inclusive Prompt photons

Inclusive prompt photon

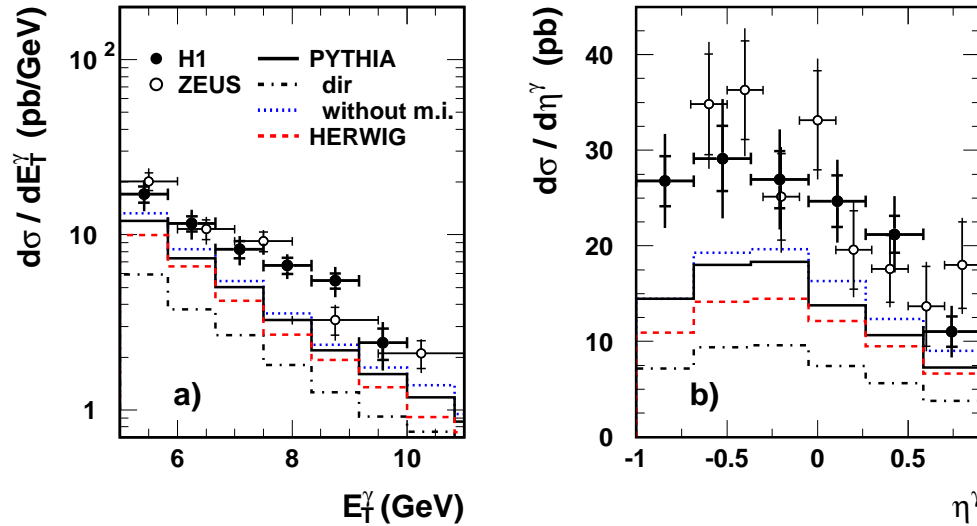

- H1 and ZEUS measurements agree within errors
- LO MC: shapes are well described, but are below data by 40 – 50%
- More than 50% of prompt photons are produced in direct γp interactions

- NLO calculations are closer to the data, but still $\sim 30\%$ below
- Mult.int. reduce cross section by spoiling γ isolation criteria
- NLO corrections are substantial, with $NLO/LO = 1.2 - 1.4$ for FGH case \Rightarrow Need for HO corrections? Else?

Inclusive prompt photon

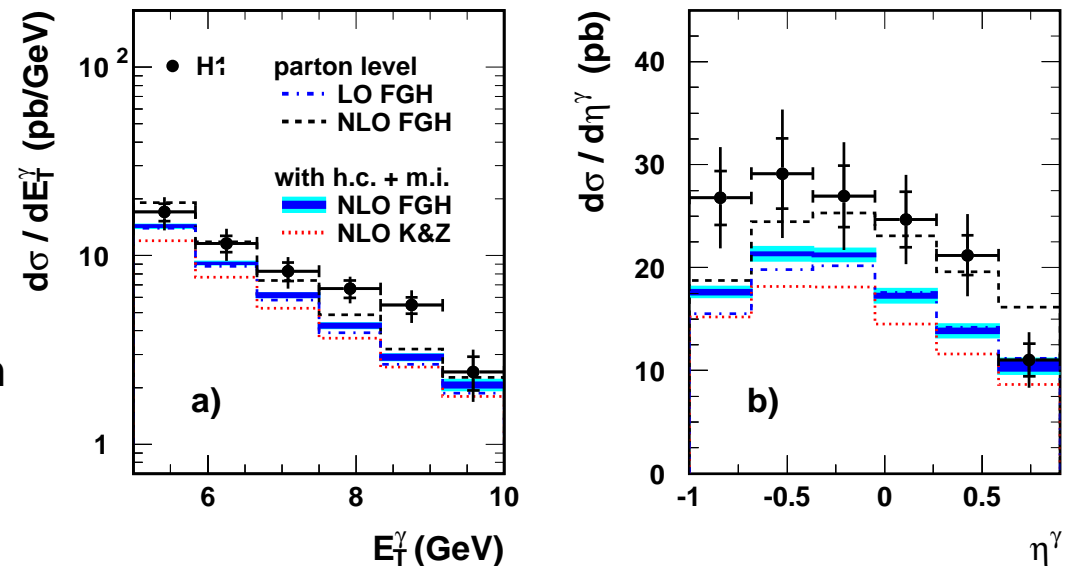

Prompt photon + jet

One possible explanation of large inclusive photon production is due to high intrinsic transverse momentum of partons in the proton, $\langle k_T \rangle$

⇒ Select γ +jet and check p_T imbalance (in direct enriched sample)

$$(E_T^\gamma > 5 \text{ GeV}, E_T^{jet} > 5 \text{ GeV}, x_\gamma^{obs} > 0.9)$$

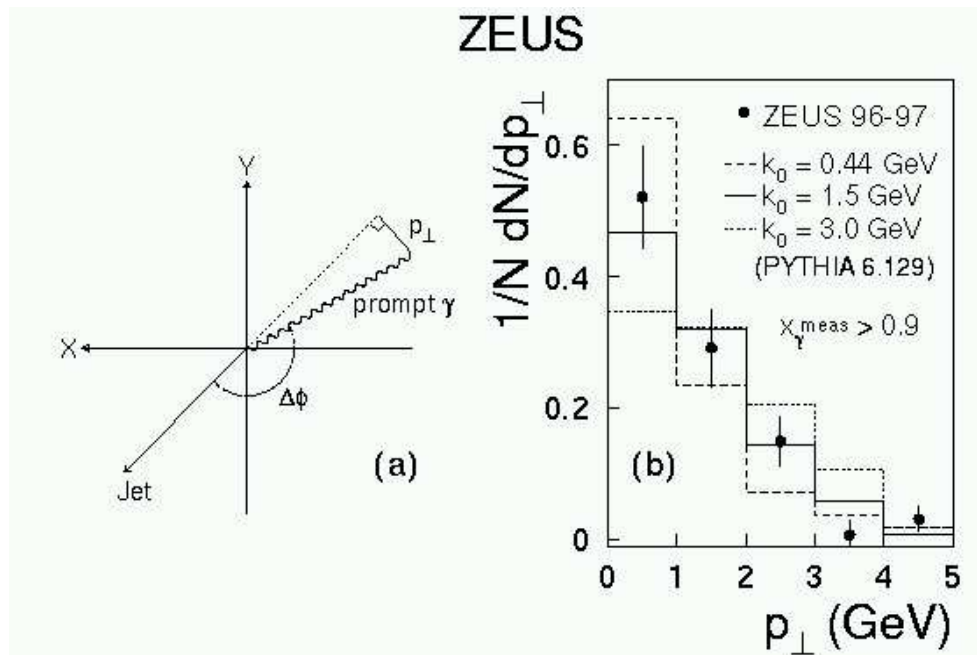

$$\langle k_T \rangle = 1.69 \pm 0.18 \pm 0.19 \text{ GeV}$$

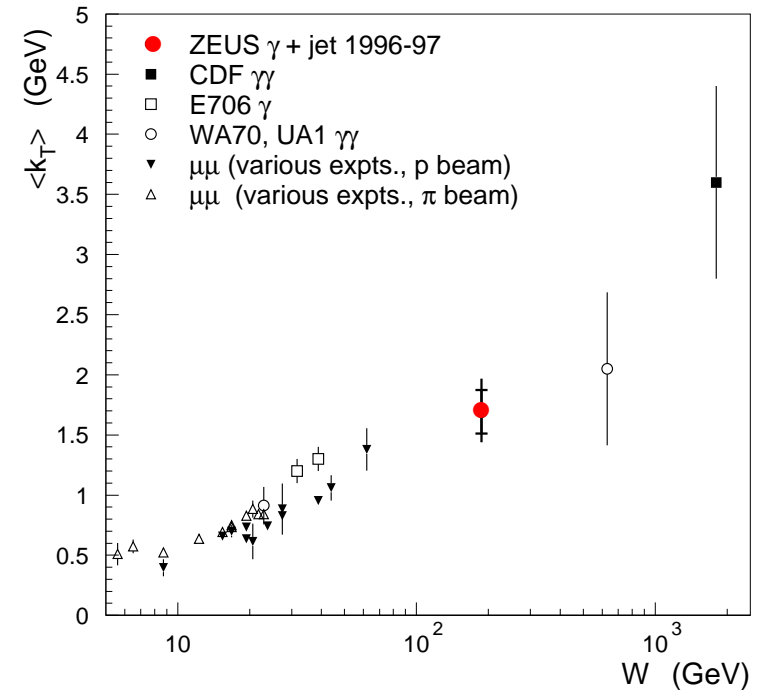

(inferred from tuned Pythia)

- ZEUS result nicely interpolates between low energies and Tevatron measurements

Prompt photon + jet vs NLO QCD

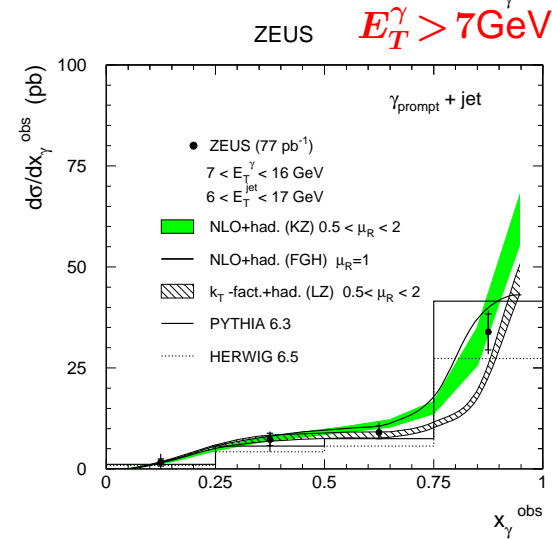
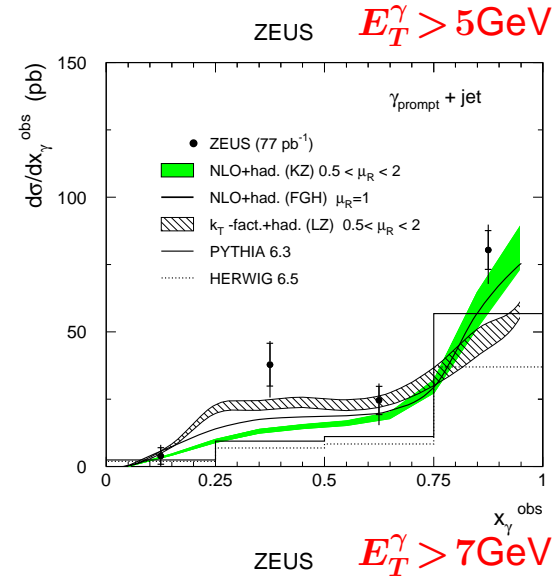
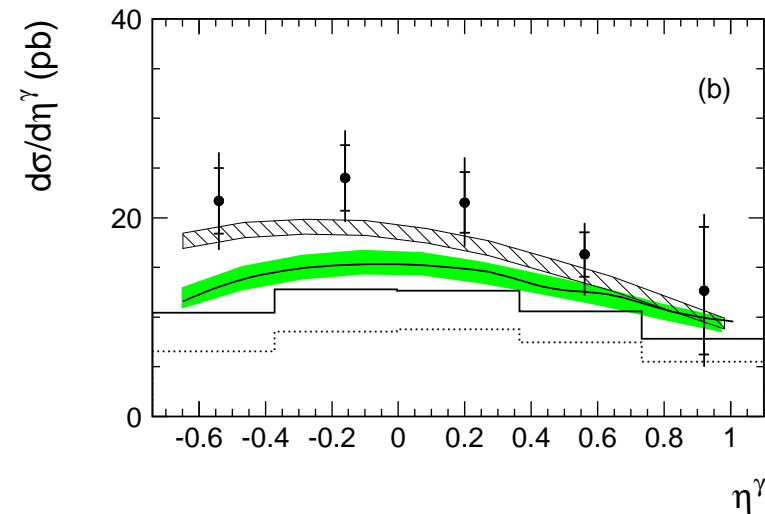
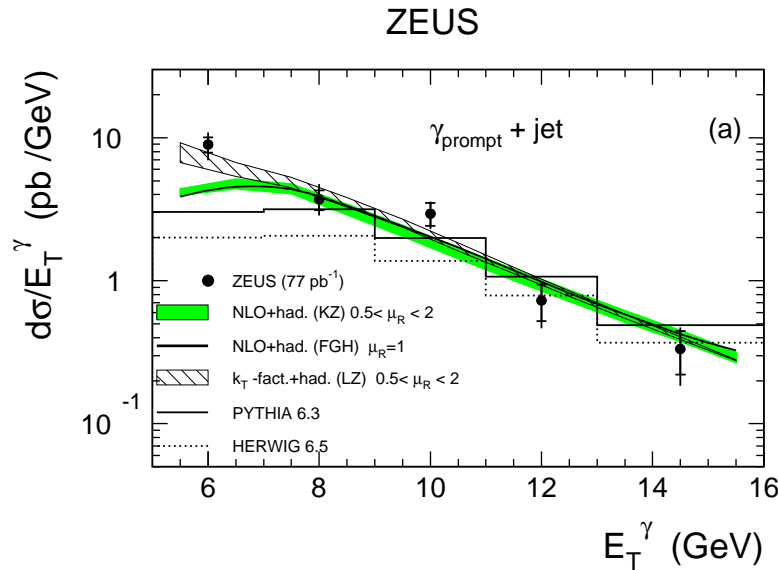

- Data sample:
 $E_T^\gamma > 5\text{GeV}, E_T^{\text{jet}} > 6\text{GeV}$

- LO MC:
fail both in E_T^γ shape
and normalisation

- In $E_T^\gamma > 7\text{GeV}$ range
all NLO calculations
agree with the data

- At low E_T^γ :
Only LZ version gives
adequate description

★ Best description is provided by NLO based upon k_T -factorisation approach and uPDFs

Charm and Beauty at HERA

- Factorisation:

Photon Structure \otimes Matrix Element \otimes Proton Structure \otimes Fragmentation

- Relevant scales:

m_Q ($m_c \sim 1.5$ GeV, $m_b \sim 4.8$ GeV)

$Q^2 < 1$ GeV² (γp) or > 2 GeV² (DIS)

$p_t^{c,b}$ ($p_t^{jet} > 6$ or 7 GeV)

but: extra theoretical systematics from scale ambiguity (multiscale problem)

- QCD interpretation:

- \triangleright NLO $\mathcal{O}(\alpha_s^2)$ calculations

- FMNR (*Frixione et al.*)

- ZMVFNS (*Binnewies et al.*)

- GMVFNS (*Kniehl et al.*)

- \triangleright (LO $\mathcal{O}(\alpha_s)$ + PS) Monte Carlo

- Pythia / Herwig (DGLAP)

- Cascade (CCFM, k_t factorisation)

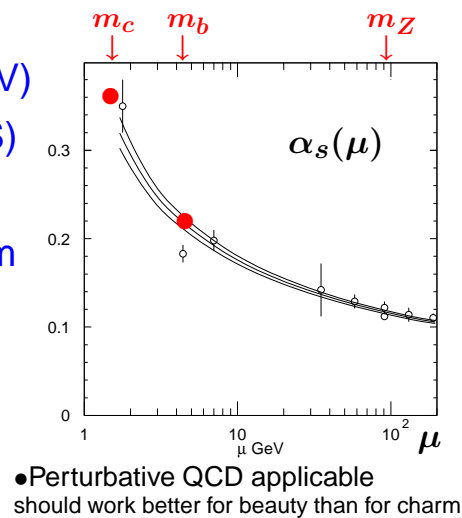

Dominant process: BGF

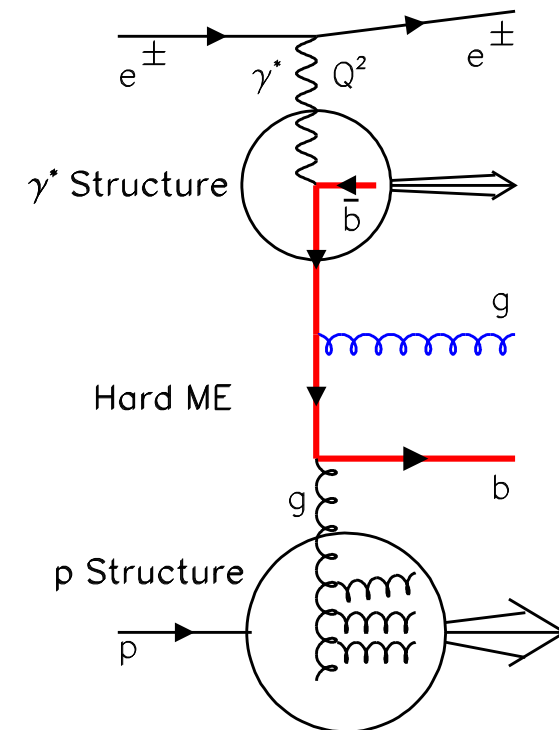

Heavy Quark Identification

- Resonance reconstruction (e.g. D^*)
- Lifetime tag (impact parameter)
- High mass tag (p_t^{rel} , jet mass)
- Lepton tag (e, μ from HQ decays)
- ...

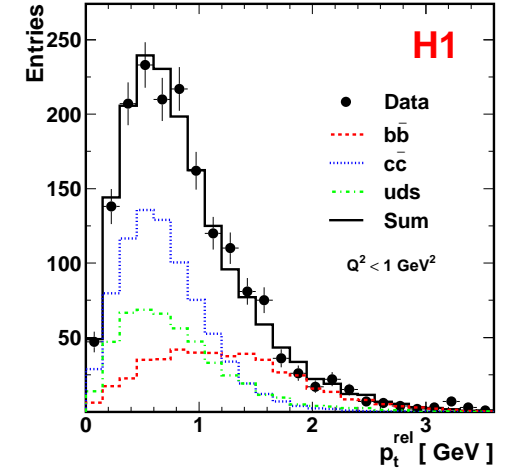
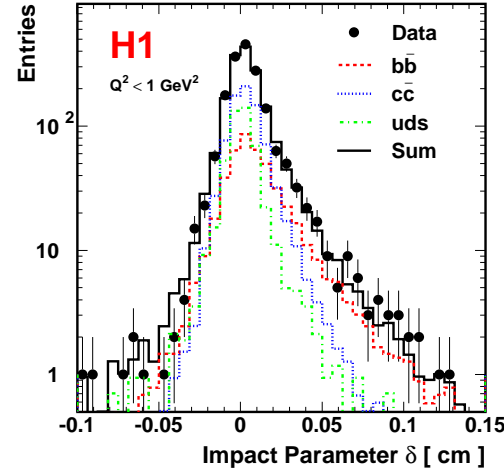

$$D^* \rightarrow D^0 \pi_s \rightarrow K \pi \pi$$

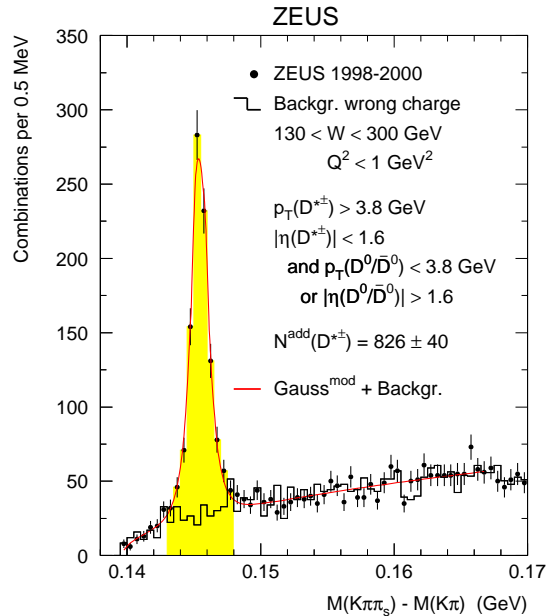

$$D_s \rightarrow \phi(\rightarrow KK)\pi$$

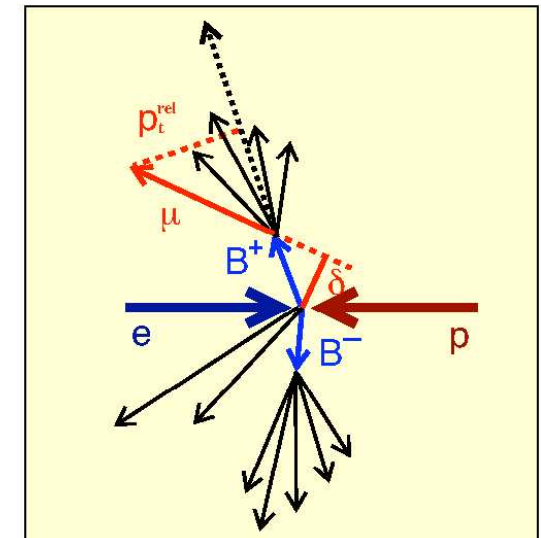
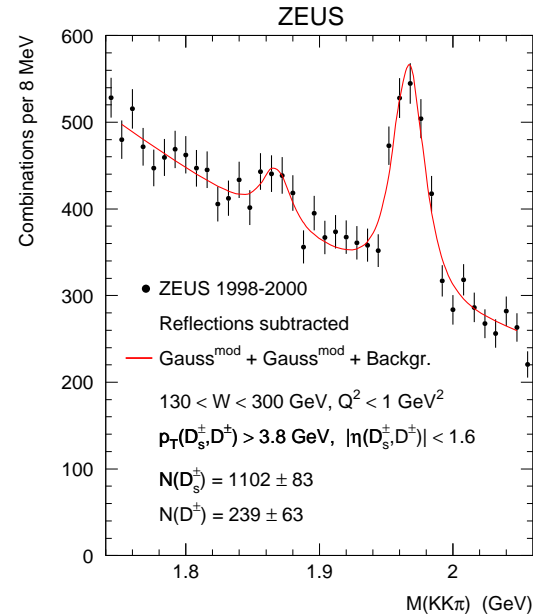

Open charm photoproduction

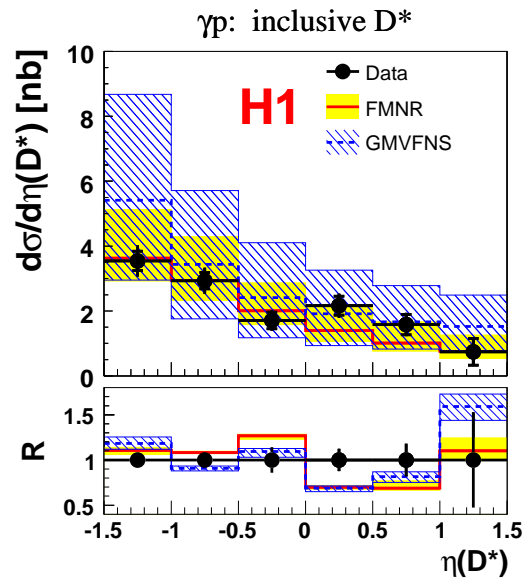

- $p_t(D^*) > 2 \text{ GeV}, E_T^{jet} > 3 \text{ GeV}, |\eta| < 1.5$

Observable	δ_{exp}	δ_{theor}
Incl. D^*	12%	35 – 50%
$D^* + \text{jet}$	15%	20 – 25%

- Charm with CVX detector (impact par. technique)

Good description over huge p_t range

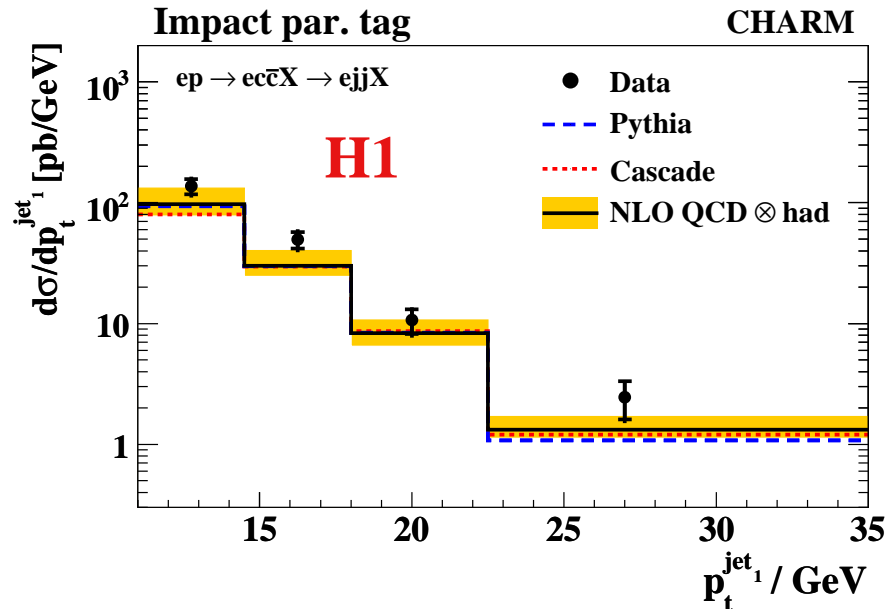
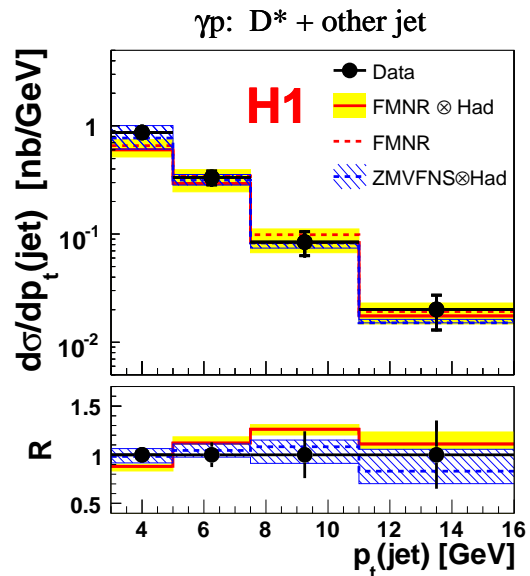

★ Inclusive D^* : NLO has problems.

★ $D^*(charm) + \text{jet}$: Fair description by NLO

$D^* + \text{jets}$

Look for deviations from back-to-back topology in $D^* + \text{jet}$ events

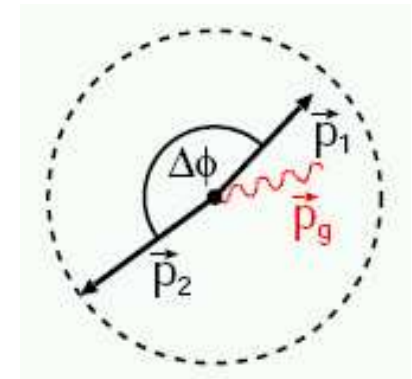
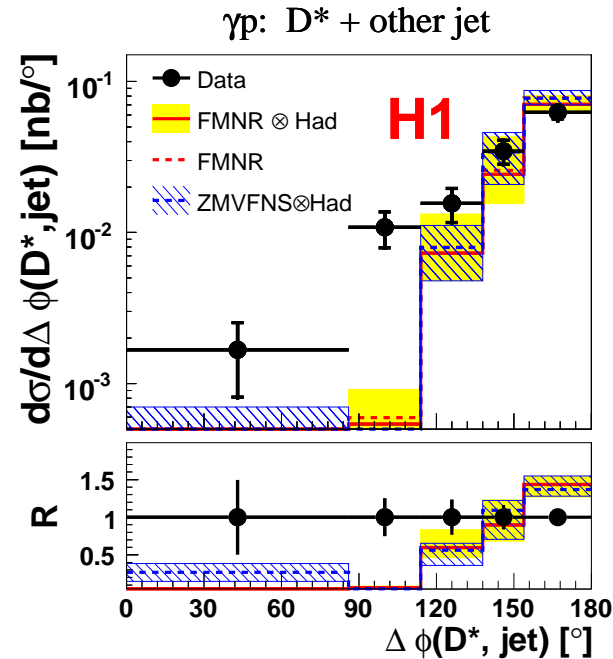
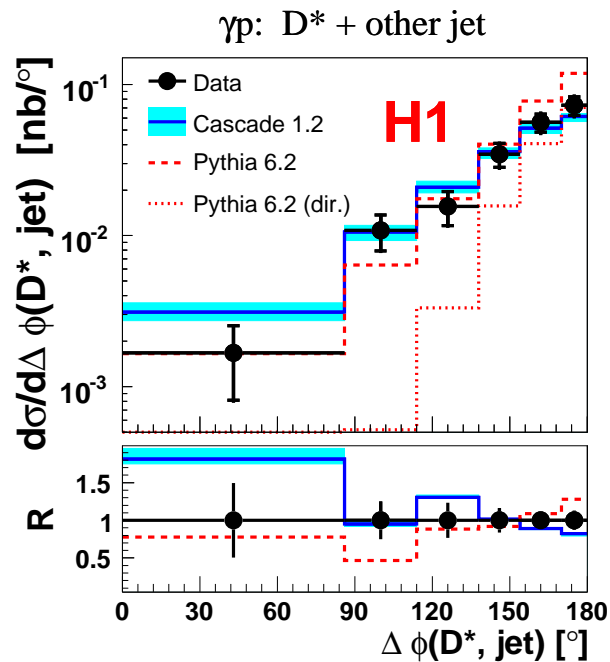

gluon radiation

LO MC emulating higher orders by means of parton showers describe azimuthal D^* -jet correlation reasonably well, while existing NLO significantly underestimate small $\Delta\Phi$ range

★ Indication of missing HO terms in NLO to describe D^* -jet angular correlations

Charm in the Photon

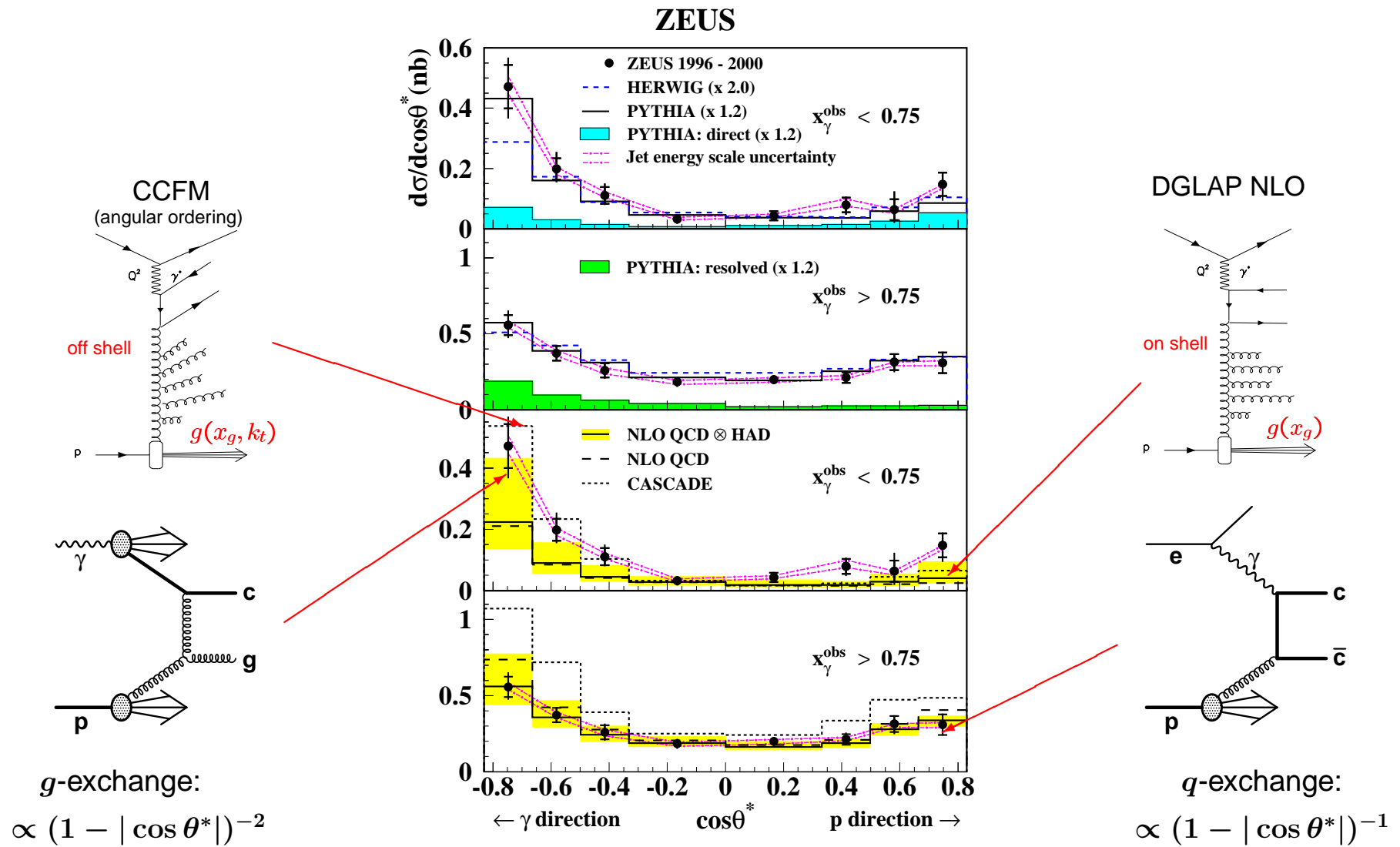

★ LO picture: Large fraction of charm originates from resolved photons

★ QCD evolutions: DGLAP is OK for $x_\gamma > 0.75$, but too low for $x_\gamma < 0.75$

CCFM (Cascade) is OK in shape, but too high in cross section

Beauty PHP at HERA

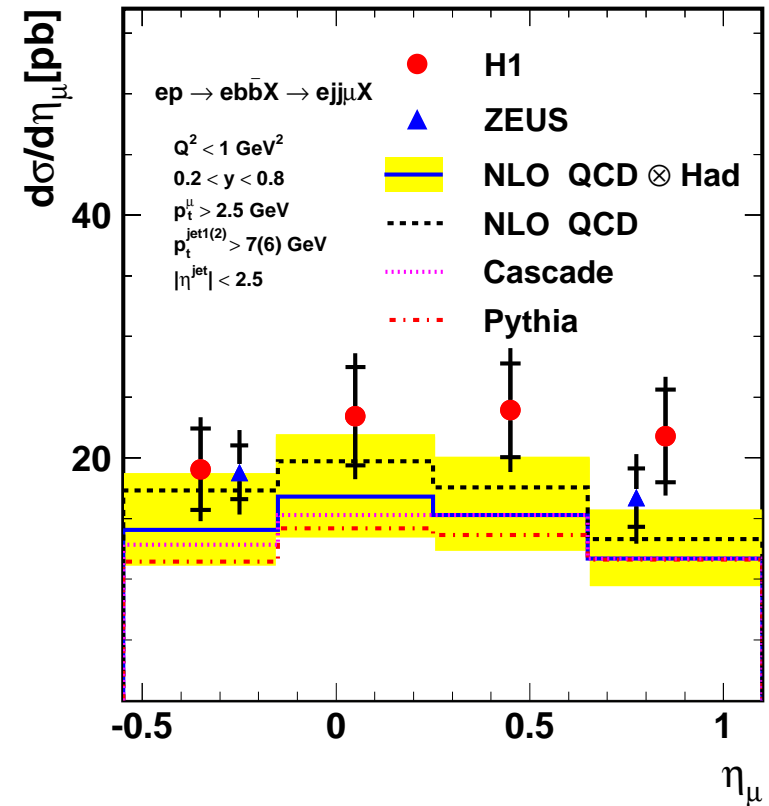
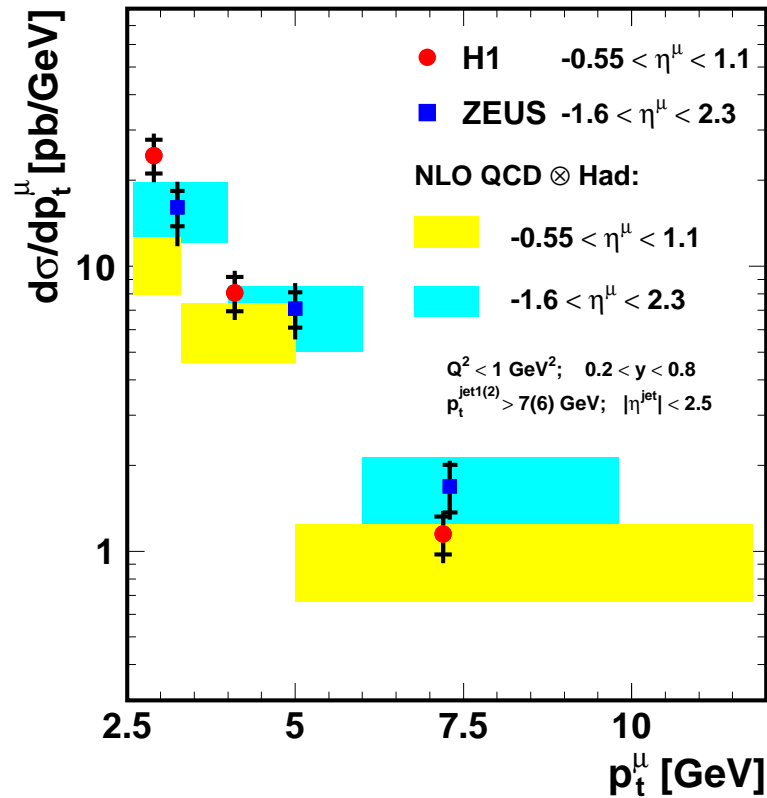

$\gamma p \rightarrow b\bar{b}X \rightarrow jj\mu X'$

• H1 and ZEUS agree in the common phase space

• LO MC underestimate cross section by $\sim 40\%$

• NLO QCD is almost OK, but after adding hadronization corrections the agreement became worse

Beauty PHP at HERA: Summary plot

HERA

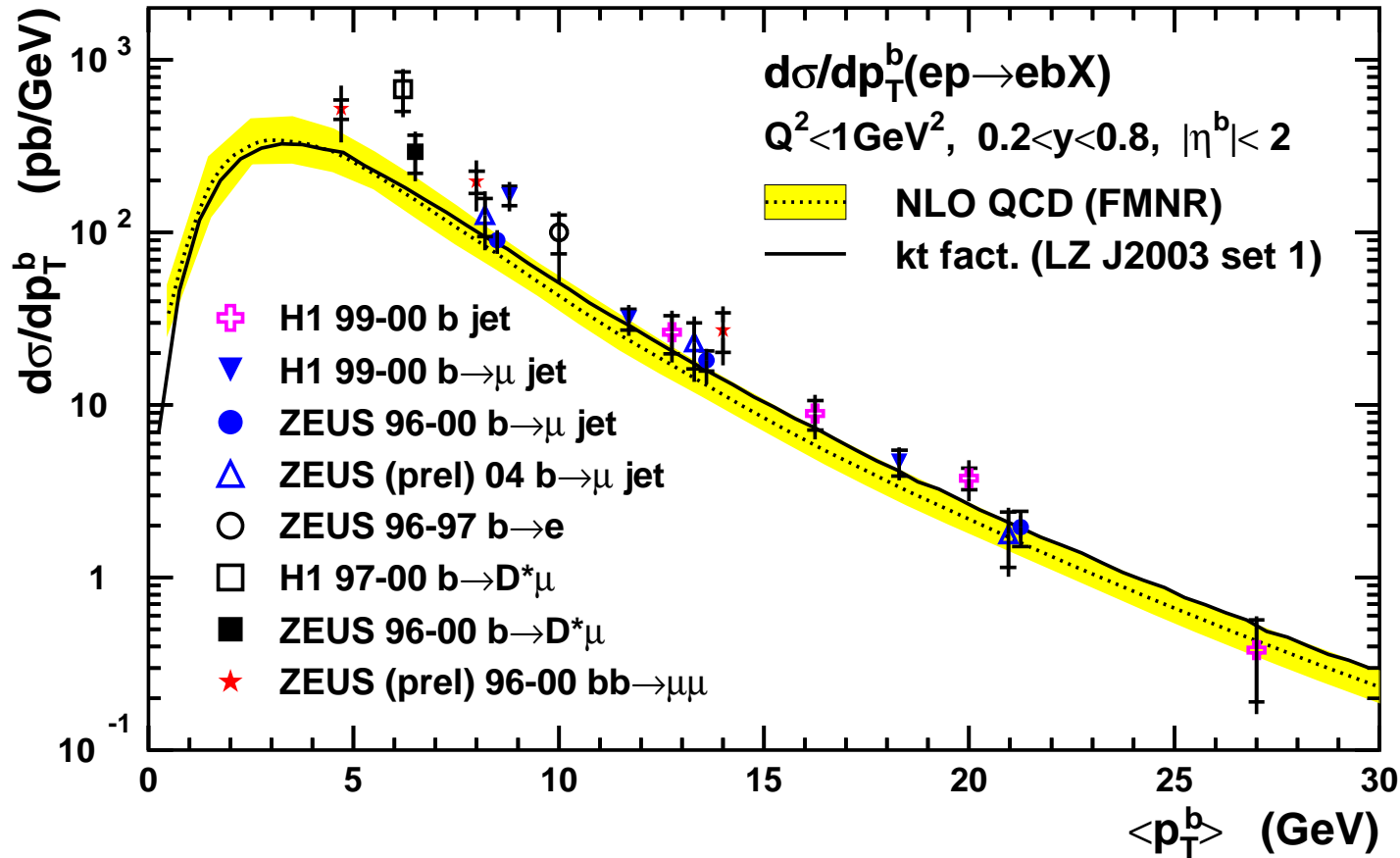

★ NLO QCD is OK for high p_t beauty production, while it tends to underestimate cross section at lowish p_t

HERA photoproduction data vs NLO: Summary

■ Jets

- **Inclusive jets:** except of low $E_T^{jet} \approx 5 - 10$ GeV range NLO describes all the data
- **Dijets:** theoretical errors now often bigger than experimental
- **Multijets:** only LO for 3-jet final state exists. Theory falls behind.

■ Prompt photons

- **Inclusive γ :** NLO corrections to LO are substantial (20 – 40%) but still insufficient: NLO is $\approx 30\%$ below the data
- **$\gamma + jet$:** for $E_T^\gamma > 7$ GeV and $E_T^{jet} > 6$ GeV all calculations are OK.
For low $E_T^\gamma = 5 - 7$ GeV only LZ calculation (using k_t factorisation scheme) is able to describe data

■ HQ

- **Charm:** D^* -jet cross sections are well reproduced by NLO, which however fails to describe inclusive D^* as well as D^* -jet angular correlations
- **Beauty:** data have a tendency to lie above NLO, but the difference is no longer as dramatic. More precise data are required to further constrain theory

Summary and Outlook

- Photoproduction at HERA is rich field of research, providing valuable and stringent test of our knowledge of QCD.
Good understanding of inclusive jets, dijets and prompt photons is achieved with NLO, which is not yet the case for heavy flavours.
- There is a clear need for higher order theoretical calculations beyond presently available $\mathcal{O}(\alpha_s^2)$, as almost for all measurements theoretical uncertainty exceeds experimental errors (α_s , inclusive photons, charm, low E_T range, multijets)
- So far only $\sim 120 \text{ pb}^{-1}$ of HERA-1 data are analysed and published. There exist 3 times larger HERA-2 data samples with improved flavour tagging and phase space coverage by upgraded H1 and ZEUS detectors.
To make best use of those we expect also corresponding progress from theory side.

BACKUP SLIDES...

Dijet cross section for $E_T^{j1} > 25$ GeV as a function of $E_T^{j2, min}$

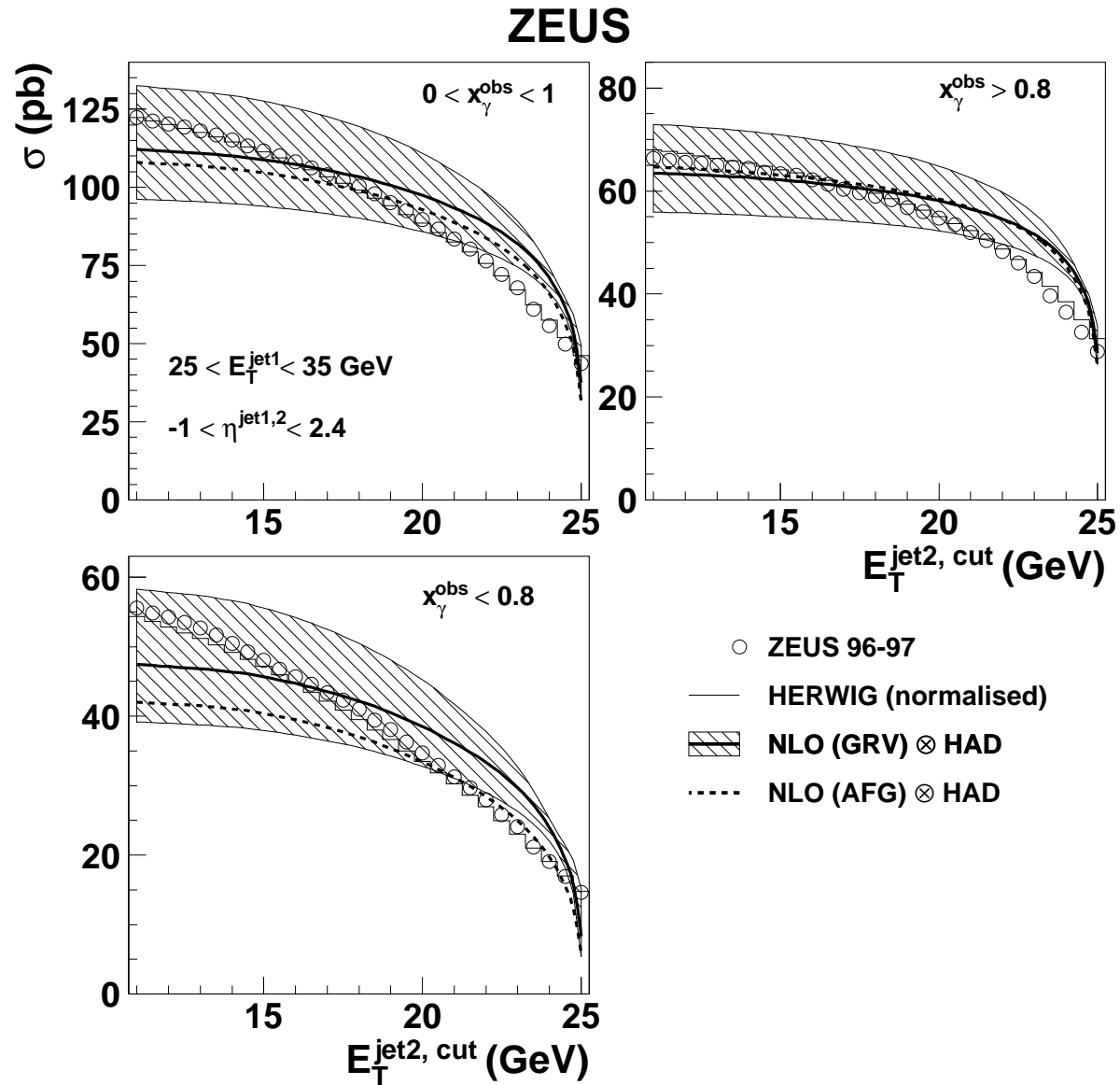

4-jet data vs MC models

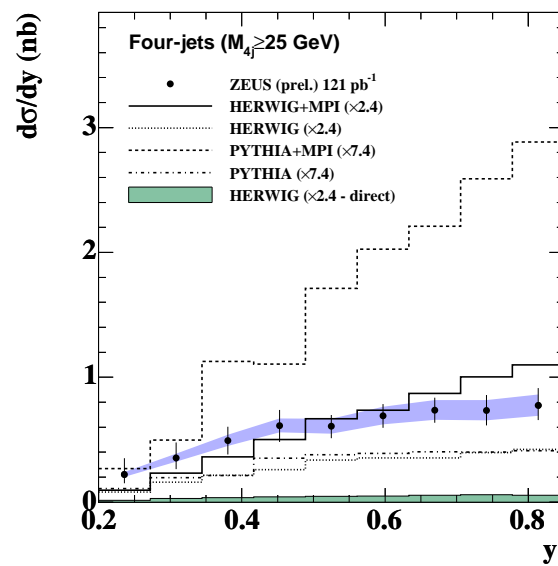
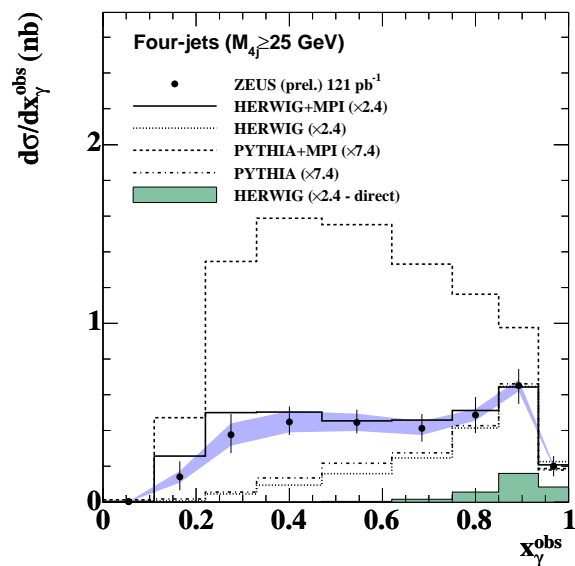
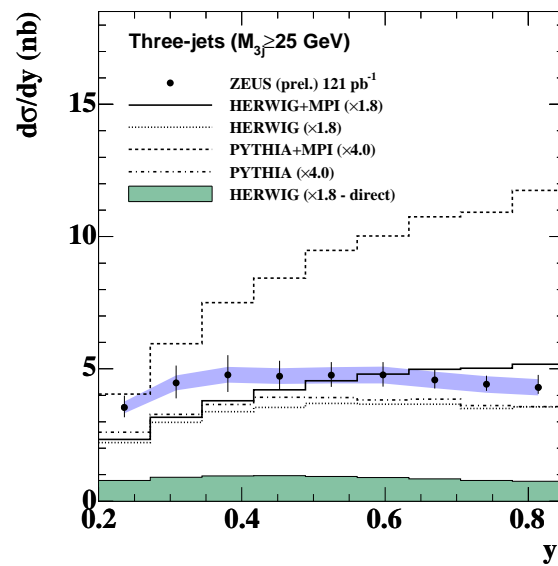
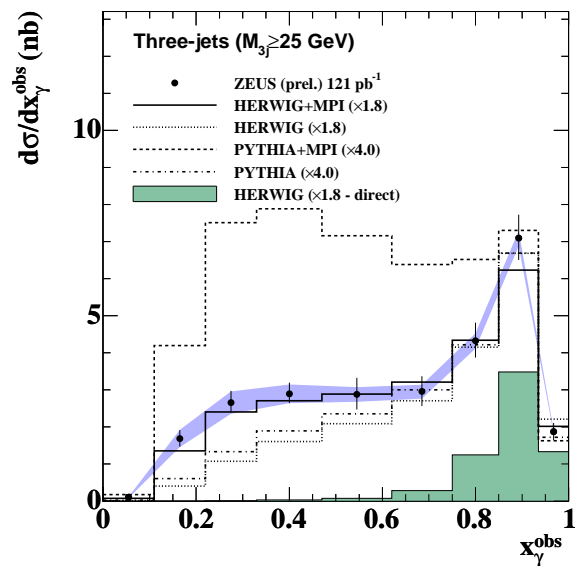

Charm fragmentation : fractions

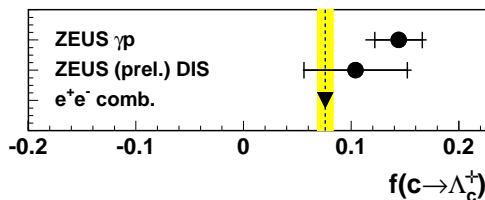
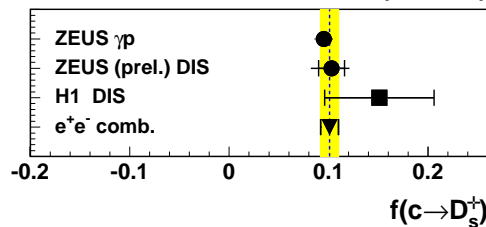
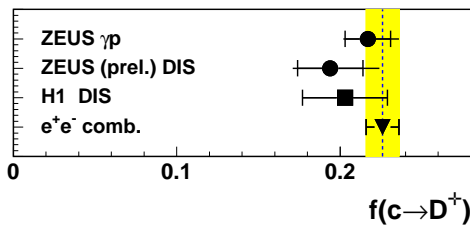
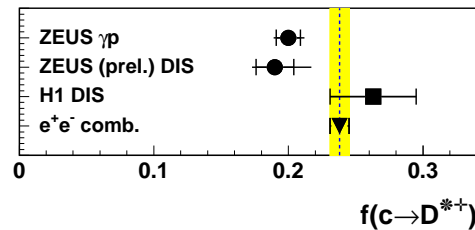
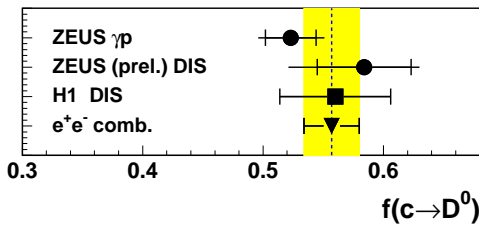

$$f(c \rightarrow D) = \frac{\sigma(D)}{\sum_i \sigma(D_i)}$$

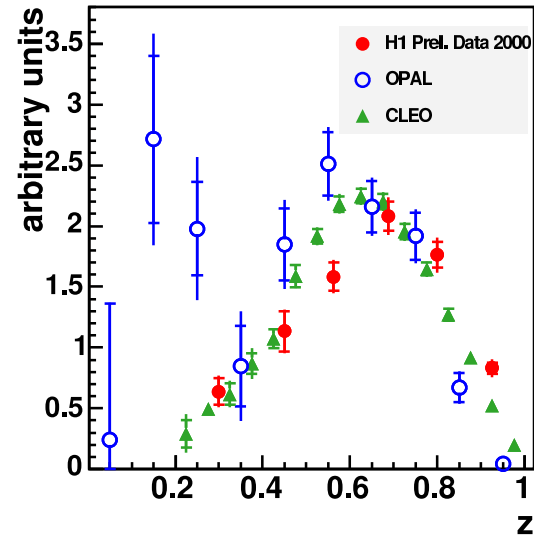

H1 hemisphere method

$$\langle \sqrt{s} \rangle \approx 10 \text{ GeV},$$

$$z = \frac{(E+PL)_{D^*}}{\sum_{\text{hem}}(E+p)}$$

OPAL $\sqrt{s} = 91.2 \text{ GeV}$,

$$z = 2E_{D^*}/\sqrt{s}$$

CLEO $\sqrt{s} \approx 10 \text{ GeV}$,

$$z = p_{D^*}/p_{\text{max}}$$

⇒ accurate measurements at HERA : errors competitive

⇒ all fragmentation fractions in agreement with world average : universality