

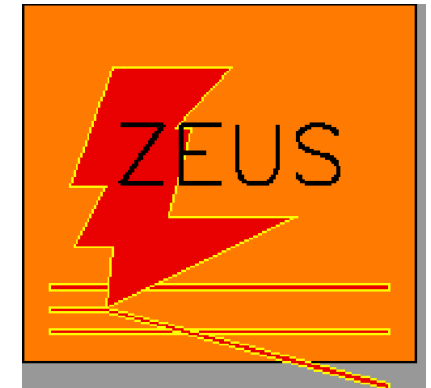

Riccardo Brugnera
Padova University and INFN

on behalf of the
ZEUS Collaboration



Measurement of the J/ψ helicity at ZEUS

Outline:

- inelastic quarkonium at HERA
- polarization measurements in PHP
- comparisons between data and various theoretical predictions
- conclusions

inelastic quarkonium at HERA

- PHP \Leftrightarrow low $Q^2 \Leftrightarrow$ electron escape undetected
- inelastic \Leftrightarrow accompanying final state hadrons

ZEUS

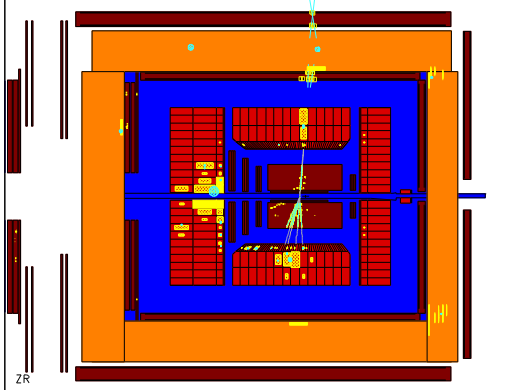
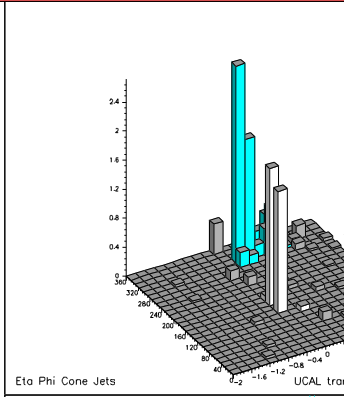
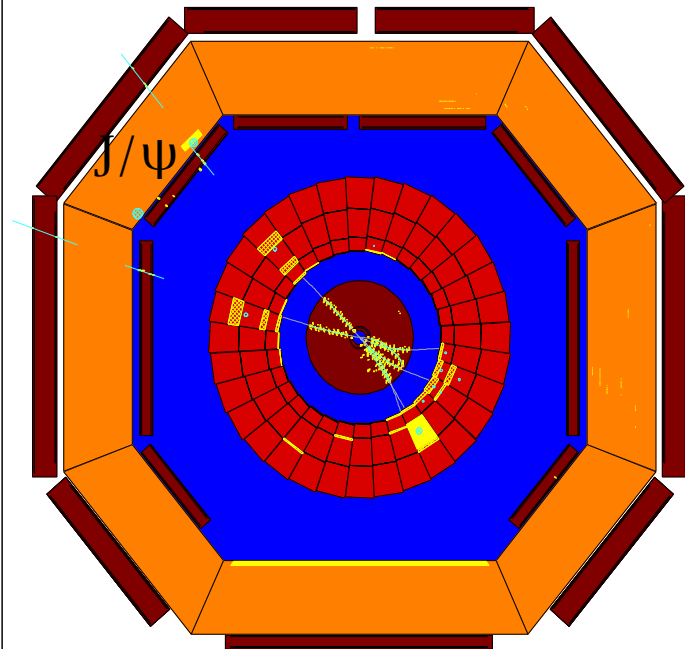
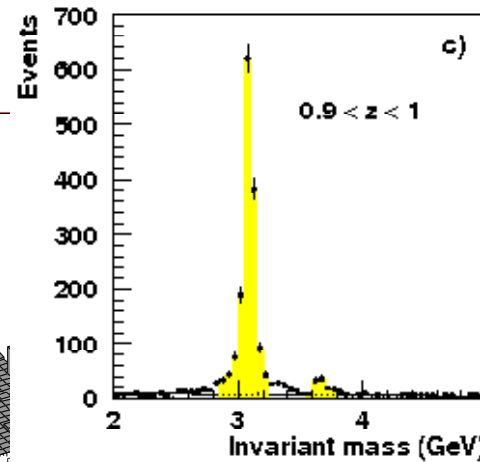
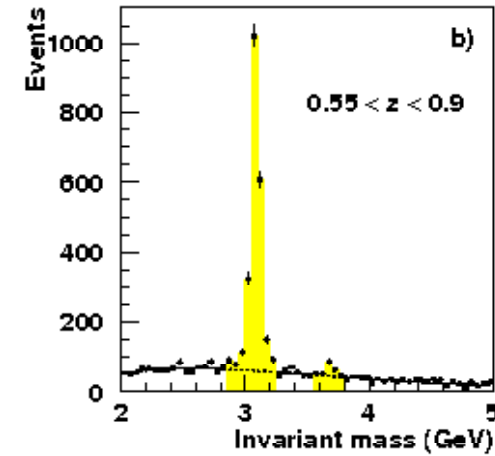
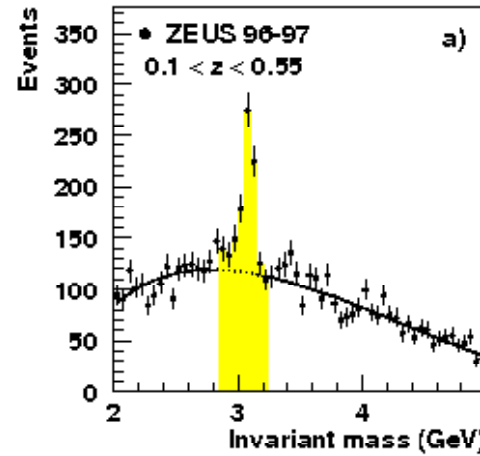

inelastic quarkonium at HERA

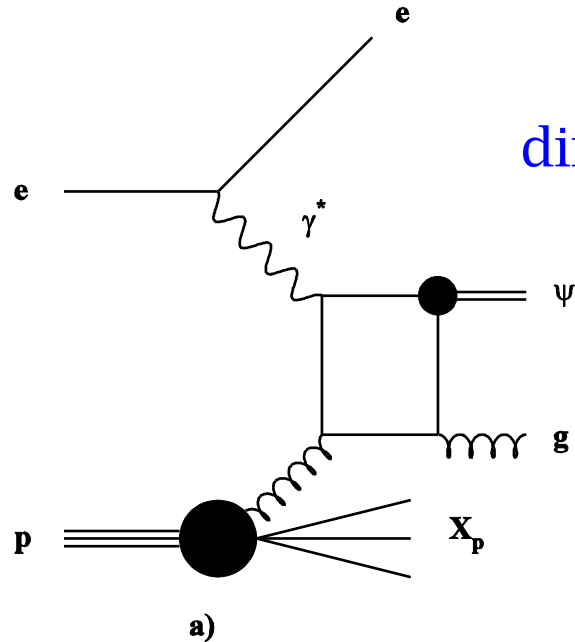

direct γ , "CS model"
 $0.2 < z < 0.9$

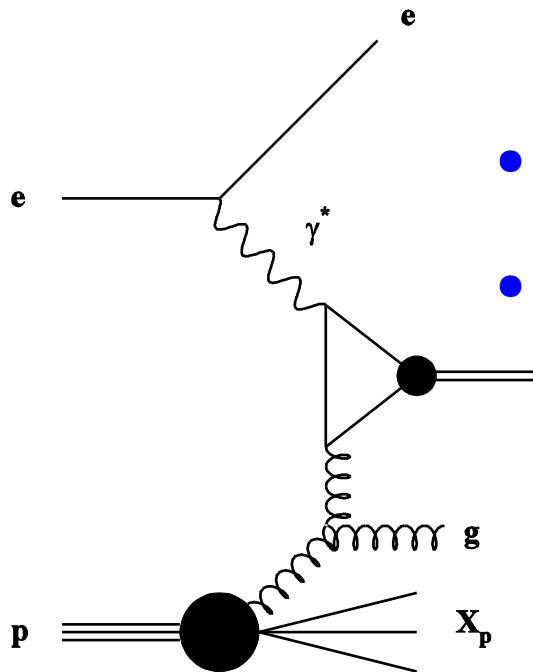

direct γ , "CO model"
 • this particular diagram
 $0.2 < z < 0.9$
 • more "typical" ones:
 $z > 0.9$

$z = E(J/\psi)/E(\gamma)$
 p rest frame

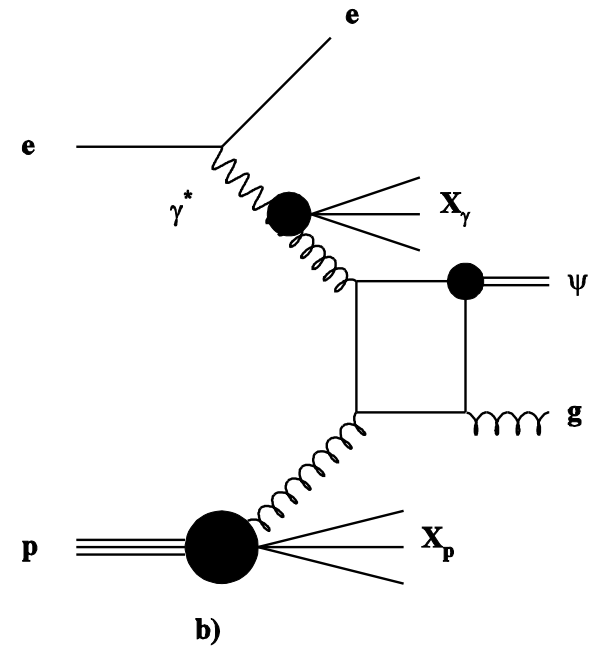

resolved γ , "CS model"
 $z < 0.2$

+ diffractive contributions:
 suppressed by cuts on the
 main kinematic quantities

cross section measurements in PHP

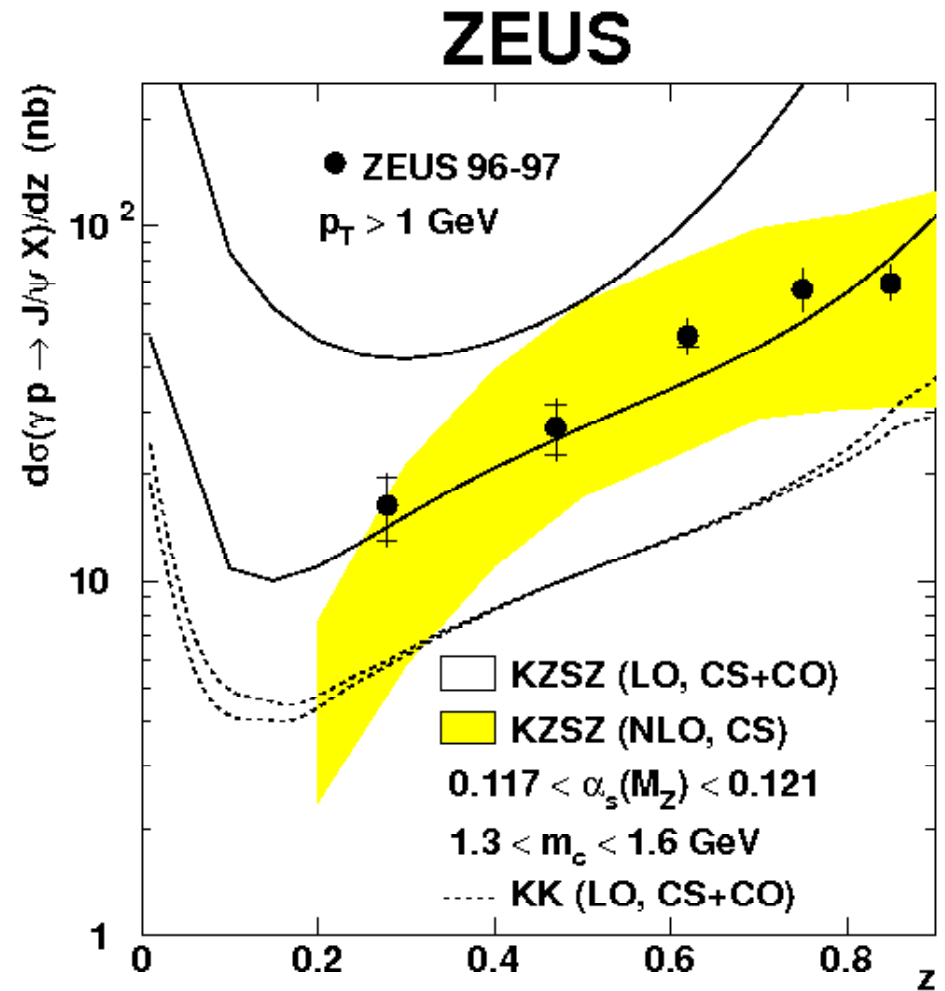
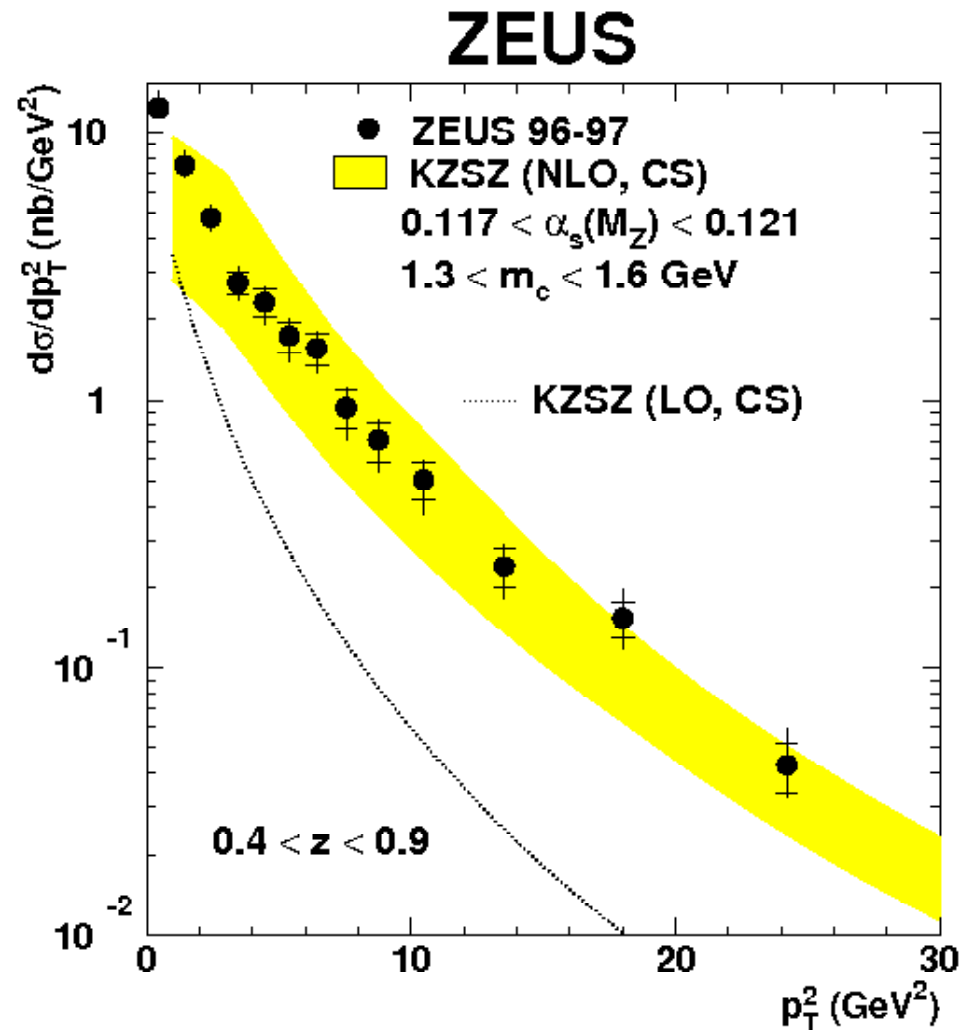

- NLO CS in good agreement but large normalization uncertainties of the theoretical predictions ...
- space for CO contributions.

polarization measurements (helicity parameters)

Main advantages:

- ◆ Since the decay angular distributions are **normalized quantities**
 —————> **largely independent** from normalization uncertainties.
- ◆ They are observables **sensible** to the different production mechanisms.
- ◆ The resummation necessary in the endpoint region, important for $d\sigma/dz$ at z close to 1, affects the decay angular distributions to a lesser degree.

Main disadvantages:

- The decay angular distributions require the use of **large data sample**.

polarization measurements (helicity parameters)

The polarization of the J/ψ can be determined by measuring the angular distribution of the leptonic decay $J/\psi \rightarrow l^+ l^-$

In general the l^+ decay angular distribution in the J/ψ rest frame is parameterized as:

(M. Beneke, M. Krämer and M. Vanttinen, Phys. Rev. D **57**, 4258 (1998)):

$$\frac{d^2 \sigma}{d \Omega dy} \propto 1 + \lambda(y) \cos^2 \theta + \mu(y) \sin 2\theta \cos \phi + \frac{1}{2} \nu(y) \sin^2 \theta \cos 2\phi$$

where y stands for a set of variables (z and $p_t(J/\psi)$ are good candidates)

- ◆ λ , μ , ν are related to the different color-octet matrix elements involved
- ◆ λ , μ , ν also depend on the definition of a coordinate system

polarization measurements (helicity parameters)

integrate the “helicity” master formula

$$\text{in } \varphi \quad \frac{1}{\sigma} \frac{d^2 \sigma}{d \cos \theta d y} \propto 1 + \lambda(y) \cos^2 \theta$$

$$\text{in } \cos \theta \quad \frac{1}{\sigma} \frac{d^2 \sigma}{d \phi d y} \propto 1 + \frac{\lambda(y)}{3} + \frac{\nu(y)}{3} \cos^2 \phi$$

◆ which frame ? frame accessible experimentally using PHP events: **target frame:**

- z axis (quantization axis): along the opposite direction of the incoming proton in the J/ψ rest frame
- x and y axis: chosen to complete a right-handed coordinate system in the J/ψ rest frame.

➤ θ : angle between the μ⁺ vector in the J/ψ rest frame and the z axis

➤ φ: azimuthal angle in the x-y plane of the μ⁺ vector in the J/ψ rest frame

polarization measurements (helicity parameters)

data **NOT** corrected for:

- ◆ $B \rightarrow J/\psi (\rightarrow \mu^+\mu^-)$ anything
(very small contribution at HERA)
- ◆ $\psi(2S) \rightarrow J/\psi (\rightarrow \mu^+\mu^-)$ anything

$$\frac{\sigma(2S)}{\sigma(1S)} = 0.33 \pm 0.01 (\text{stat.})_{-0.02}^{+0.01} (\text{sys.})$$

$$BR(2S \rightarrow 1S + X) = (55.7 \pm 2.6)\% \quad [\text{PDG}]$$

$\psi(2S) \rightarrow J/\psi$ anything / $J/\psi \sim 15\%$

“dilute” the polarization

ZEUS

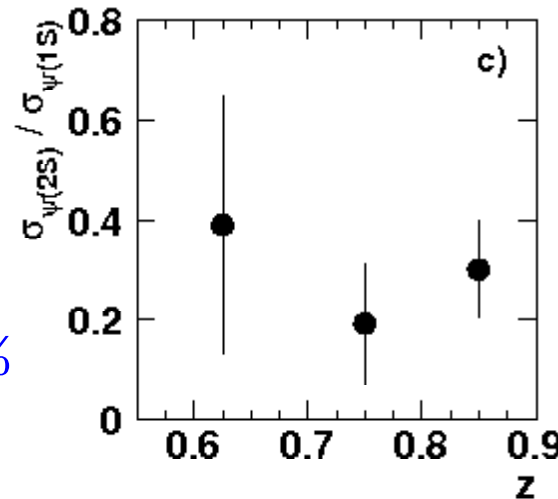
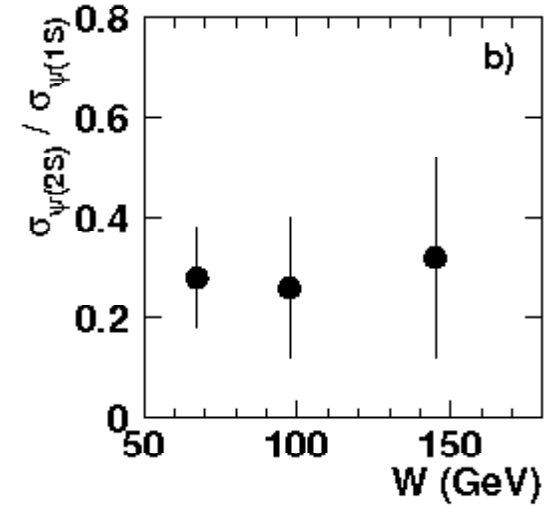
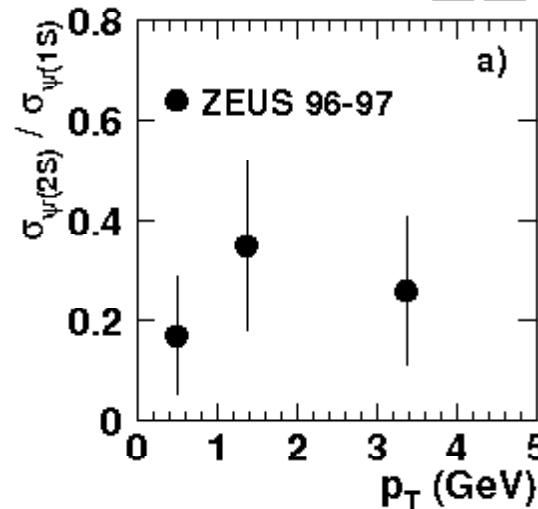

38 pb^{-1}

$< 1/10$ of what
we have now

➤ experimentally it is **very difficult** to perform reliably these corrections

comparison between pol. measurements in PHP and NRQCD (CS +CO) calculations

- ◆ Theoretical curves from: M. Beneke, M. Krämer and M. Vanttinen, Phys. Rev. D **57**, 4258 (1998).
- ◆ The calculations are made following the nonrelativistic QCD (NRQCD) approach:

$$d\sigma(H+X) = \sum_n \hat{\sigma}(c\bar{c}[n]+X) \langle O^H[n] \rangle$$

$\hat{\sigma}(c\bar{c}[n]+X)$ \equiv short-distance cross sections calculable pert. in α_s

$\langle O^H[n] \rangle$ \equiv matrix elements, non-pert. trans. probabilities from the $c\bar{c}$ state n into the charmonium H . Their size depends on the intrinsic velocity v of the bound state.

- ◆ The leading term in v coincides with the CS model.
- ◆ The calculations are made at LO
- ◆ The values and uncertainties of the matrix elements (which are universal functions) are extracted from experiments (TEVATRON, fixed target hadroproduction, $B \rightarrow J/\psi X$)

polarization measurements in PHP

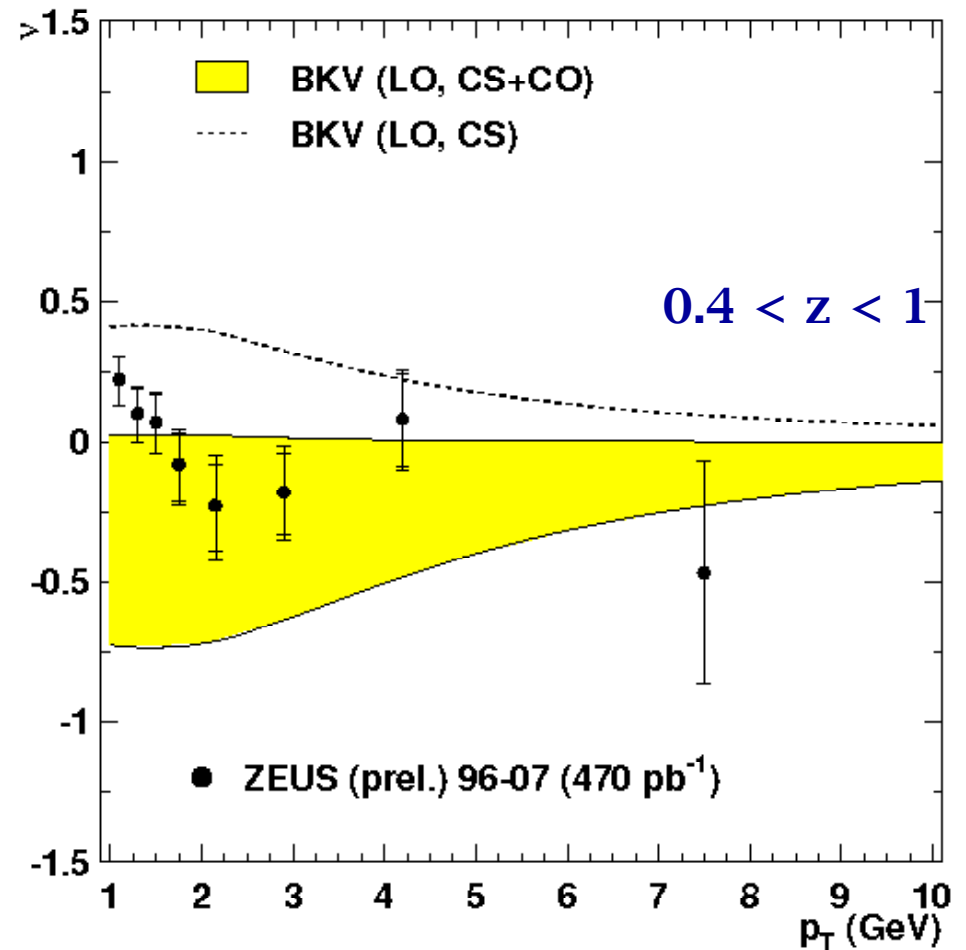
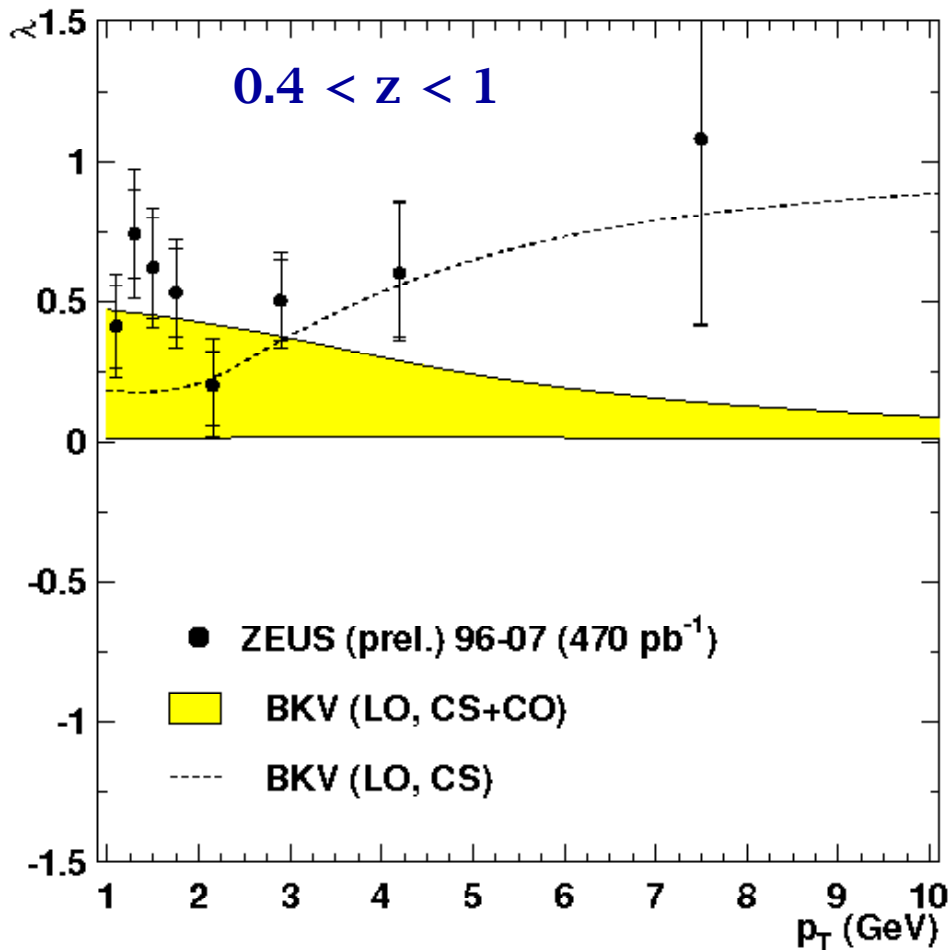

- full data sample (HERA-I + HERA-II) \Rightarrow stat. uncertainties dominate.
- high p_T region difficult to access at HERA.
- λ : the data seem to prefer transverse polarization ($\lambda = +1$) as CS model predicts.
- ν : rough agreement between data and CS+CO predictions.

polarization measurements in PHP

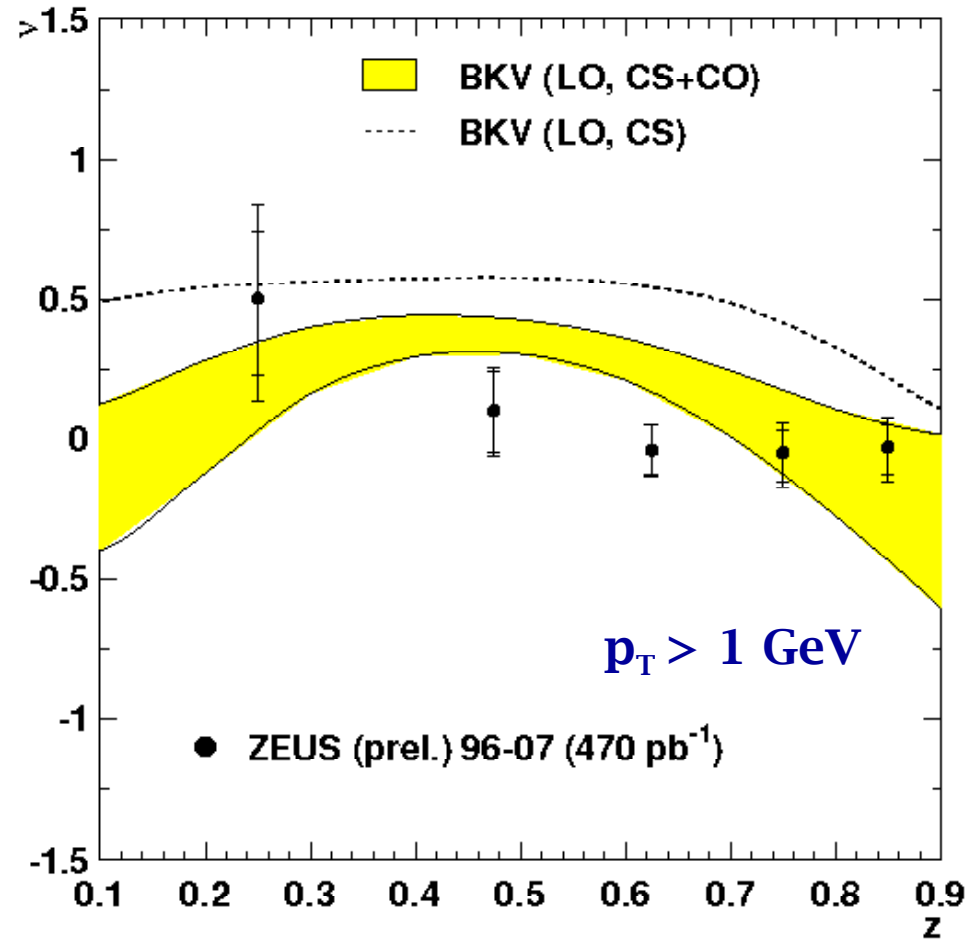
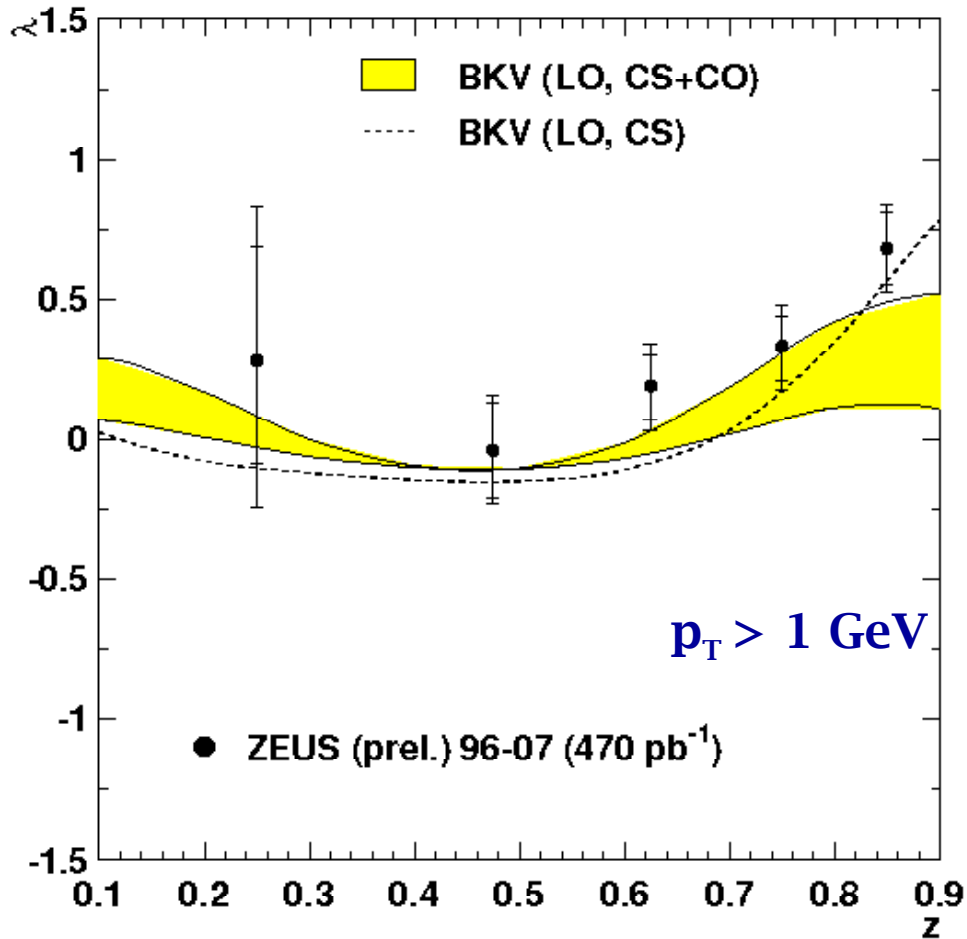

- λ : good agreement between data and theory (but poor discrimination power between CS and CO components).
- ν : do not see the positive values expected in the CS model.

comparison between pol. measurements in PHP and k_t factorization calculations

- Theoretical calculations by S.P. Baranov (private communication).
- Only CS contribution taken into account. (S.P. Baranov, Phys. Lett. B428, 377 (1998)).
- Two different parametrizations of unintegrated gluon distributions (GRV collinear gluon density as starting point):
 - **JB**: represents a solution to the leading-order BFKL equation obtained in the double-logarithm approximation (J. Bluemlein, J. Phys. G19, 1623 (1993); DESY report 95-121 (1995)).
 - **dGRV**: is derived from the collinear gluon density $G(x, \mu^2)$ by differentiating it with respect to μ^2 and setting $\mu^2 = k_t^2$.

new polarization measurements in PHP and k_t factorization calculations

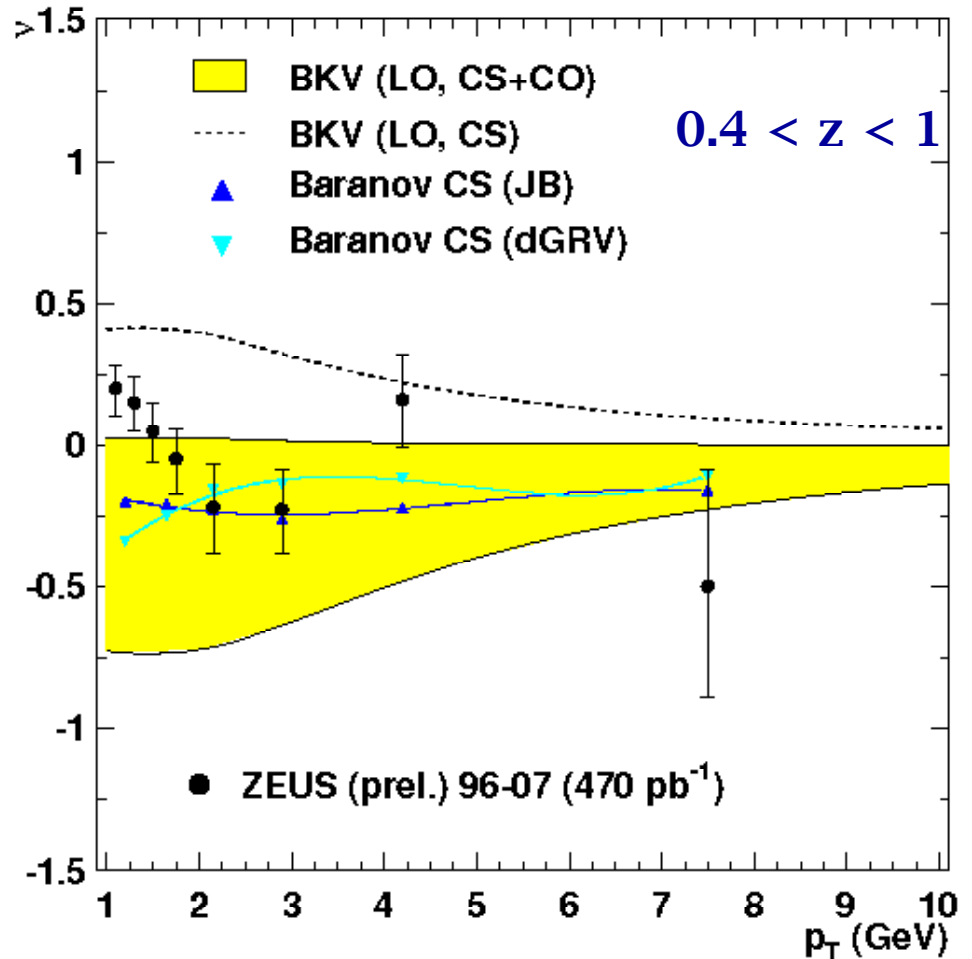
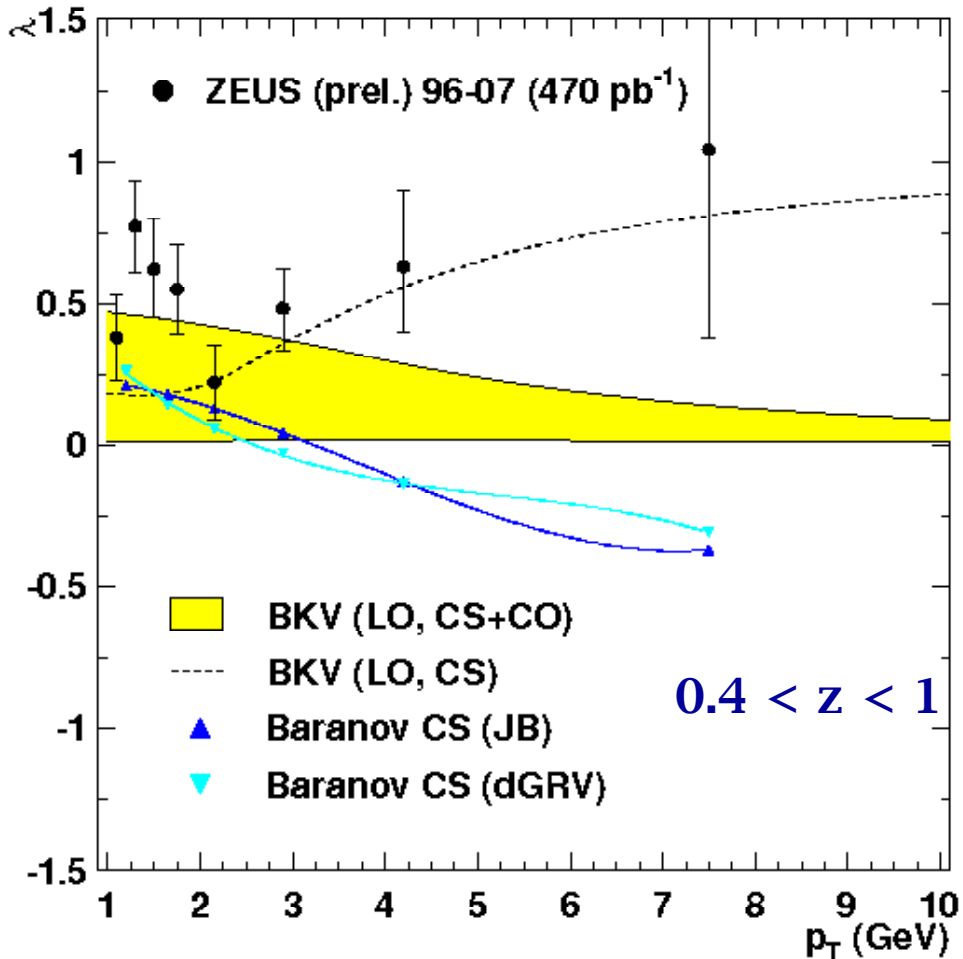

- λ : the model predicts substantial longitudinal polarization ($\lambda \Rightarrow -1$), in disagreement with the data.
- ν : rough agreement with the data.

new polarization measurements in PHP and k_t factorization calculations

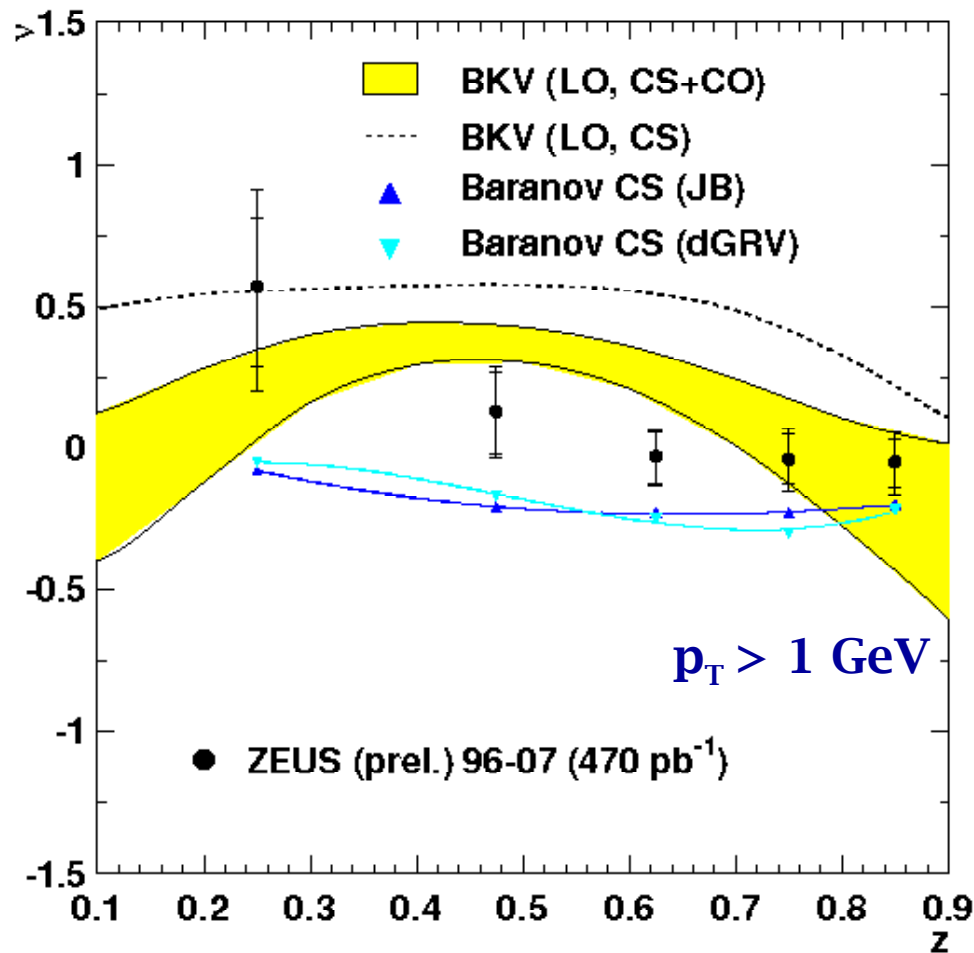
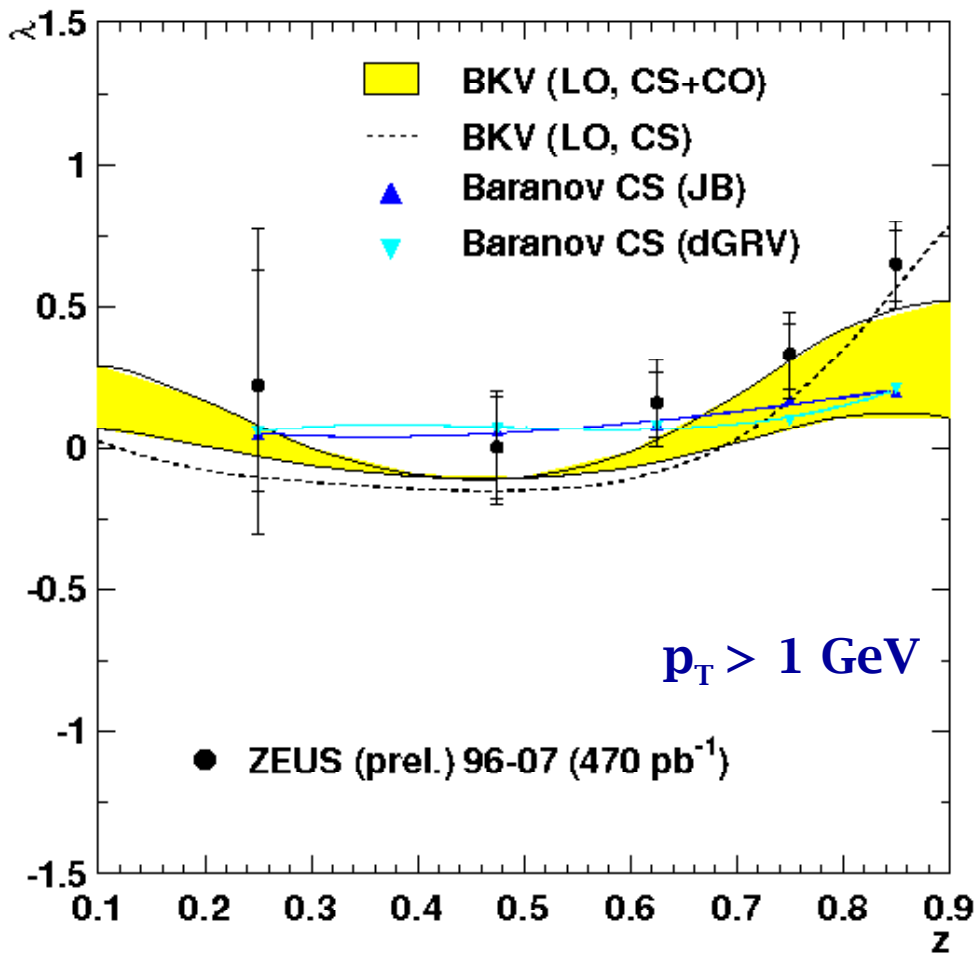

- λ : good agreement between data and k_t factorization predictions.
- ν : k_t factorization always below the data.

Conclusions

- the ZEUS helicity measurement has been updated with all the HERA available statistics (470 pb⁻¹).
- the comparison of these data with the available theoretical predictions (CS at LO, CS+CO at LO, CS in the k_t framework) is not completely satisfactory.
 - ◆ CS at LO describes λ parameter both vs. p_t^2 and vs. z , but doesn't describes ν parameter.
 - ◆ CS+CO at LO describes ν parameter both vs. p_t^2 and vs. z and λ vs. z but doesn't describe λ parameter vs. p_t^2
 - ◆ CS with k_t factorization gives predictions similar to CS+CO at LO.
- ZEUS helicity data are compared to LO predictions ... can the theory be improved in this respect ?